

# The British Sundial Society

---

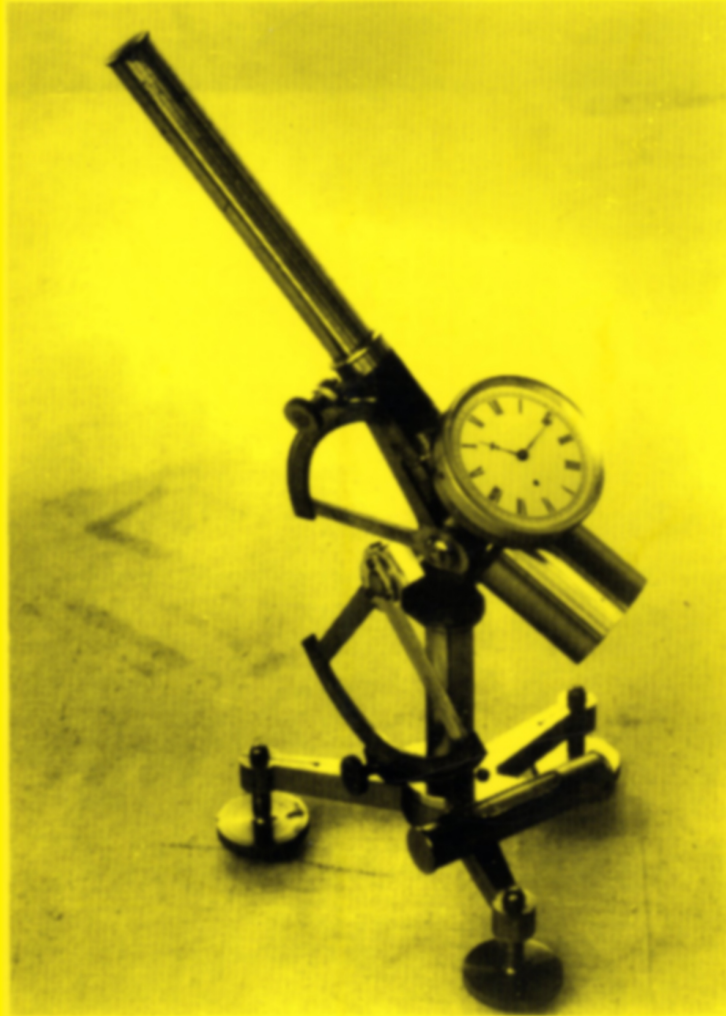

# BULLETIN

No. 93.1



FEBRUARY 1993

ISSN 0958-4315

# HONORARY OFFICIALS OF THE BRITISH SUNDIAL SOCIETY

PATRON: THE RT. HON. THE EARL OF PERTH P.C.  
PRESIDENT: SIR FRANCIS GRAHAM-SMITH  
VICE-PRESIDENT: M. RENÉ R.-J. ROHR (France)  
VICE-PRESIDENT: DR. MARINUS J. HAGEN (Netherlands)

## COUNCIL:

CHAIRMAN: MR. CHRISTOPHER ST. J.H. DANIEL  
GENERAL SECRETARY: MR. DAVID YOUNG  
FINANCE: MR. R. A. NICHOLLS  
MEMBERSHIP: MR. ROBERT B. SYLVESTER  
BULLETIN EDITOR: MR. CHARLES K. AKED  
DIAL RECORDING: MR. GORDON E. TAYLOR  
EDUCATION: MRS. JANE WALKER  
LIBRARY AND RECORDS: MRS. ANNE SOMERVILLE

---

## BULLETIN 93/1 - FEBRUARY 1993 - CONTENTS

### Page

1. DIALOGUE - De Zonnewijzerkring, Analemma, Commission of Sundials, Paris.
  2. Domifying Circles - Astronomy and Astrology, by Graham Stapleton.
  3. Some Reflections on Neolithic Astronomy, by René R.J. Rohr.
  8. A Word from the Editor.
  9. Vietnam Veterans Memorial, by Charles K. Aked.
  17. Further Progress on the Sundial Register, by Ian Wootton.
  18. The Meridians of St Sulpice Church, Paris, (Part 1), by G. Camus, P. de Divonne, A. Gotteland and B. Taillez (France).
  26. Bath Conference, September 1992, by David Brown.
  28. An Unusual Variety of Equatorial Sundial, by R.A. Mills.
  30. Sir Charles Wheatstone's Solar Chronometer.
  31. The Tower of the Winds, Athens (addenda), Charles K. Aked.
  32. The Equation of Time - Nonomol.
  34. Letters to the Editor.
  36. Bifilar Gnomonics, by Frederick Sawyer III.
- Inside back cover - Useful Addresses

Cover Illustration - Wheatstone's Solar Chronometer made by Elliott of London, mid-19th century.  
A brief description of the instrument will be found on page 30 of this issue.

## DIALOGUE

### DE ZONNEWIJZERKRING

Bulletin 92.5 is another information-packed issue. An account is given of the De Zonnewijzerkring Summer excursion on 20 June, when a visit was made by coach to various dials in Zwelle and its surroundings. There appears to be a great wealth of dialling material in this area.

A special exhibition was held at Hengelo, and De Zonnewijzerkring members loaned about sixty sundials for this.

An interesting story is related about the difference in time in the Netherlands in the last century. The railways used Amsterdam time based on local solar time, whereas the city of Utrecht used the Cathedral time. After a detachment of troops missed a train because of this difference in time, the Burgomaster of Utrecht decreed that the cathedral clock should be advanced by three minutes, and after a few months it was adjusted to Amsterdam time permanently.

A mathematical article deals with the signs of the Zodiac, whilst another deals with a problem involving the gnomon. There is a discussion on the value of  $15^\circ$  per hour for the sun's movement; and a description in English of the Sibton Abbey Venetian Ship dial now at the National Maritime Museum. This includes a number of illustrations.

An article of unusual interest is that on Moon dials, it contains mention of the dial at Queens' College, Cambridge. There is a follow-up on some correspondence about planetary time and a reproduction of the letter heading of the Foundation of Notaries in the Netherlands which shows a sundial.

The list of Netherlands sundials is constantly being added to and in this issue nine pages are devoted to recording new ones found, together with illustrations. In addition an illustration is given of a complicated dial in Mallorca. Seven pages are devoted to book reviews and periodicals, and in conclusion there is a two-page table of the Equation of Time, and Sun's Declination, for 1993.

NOTE: It is the Editor's intention to seek permission to reproduce the article on the Venetian Ship's dial because of its importance.

### ANALEMMA

Issue No. 4 for February-April 1992 is a 25 pages bulletin and contains several interesting articles. The result of the problem set in the previous number about the Mafra Polyedric Sundial is given on page 2, with a drawing of the proposed gnomons. M M Valdes explains how Jacques Ozanam applied the "Analema Novum" of Père de Saint Rigaud devised about 1656 to design his "Portable Rectilinear and Universal Sundial", of which the Capuchin dial is but a particular case of the former.

Self-orientating sundials are analysed by J Veillilla to determine the circumstances and conditions necessary to allow self-orientation of a single or set of dials. Of ten proposed combinations, he finds only three that are useful for the purpose. On page 10 an error in the reading of a sundial date as 1537 was the start of research in Santa Domingo which resulted in the dial being found but dated 1753. It was erected by the Spanish Governor Brigadier D Francisco Rubio y Penaranda and still functions.

A de Vincente, on page 13, shows mathematically how to determine the time for the solar disc to traverse a given plane. In a new section of the bulletin, M Losot demonstrates how to construct a horizontal dial without the use of trigonometrical tables and protractors, also L Hidalgo explains how to design both vertical and declining vertical sundial by experimental methods. On page 19 a computer listing in BASIC is given for calculating the hour lines for a horizontal dial. The noon time analemma is included.

P Dantillo illustrates some literary texts which include the word "sundial". Finally the Editor gives a resumé of the articles in the issue plus a very welcome set of English abstracts.

The Association of Friends of Sundials was created in April 1988, its President is Luis Hidalgo Velayos, the Secretary is José Ramon Marcet Roig. The information Officer is Jesus de la Calle Montes, and the address of the Society is:

Asociacion de Amigos de los Relojos de Sol  
Escuela Tecnica Superior de Ingenieros Agronomos  
Ciudad Universitaria, 28040 - MADRID, SPAIN

The Editor regrets that he does not know the entry requirements, nor the subscription cost. The text is, of course, in Spanish. If anyone is interested, photocopies of the required information can be supplied at cost plus postage charges.

### COMMISSION OF SUNDIALS, PARIS

Details of the October 1992, 15th reunion of the Commission des Cadran Solaires, Paris, were received recently. Of the total membership of 105 (September 1992), 36 attended the meeting. M Savoie, President, in opening the meeting recalled that the Commission had been founded twenty years ago.

Mention was made of the activities of the Commission, evidently many requests for information are made and answered. M Opizzo had given a talk on magnetic compasses used with sundials. Many items were discussed, including the astronomical symbols used in gnomonics.

The afternoon session opened with M Savoie mentioning the many brochures on sundials received. The microfiche records of sundials compiled by the previous President, M Sagot, had been duplicated as a safeguard; over 8,000 fiches were involved. This is going to be published in a simplified version. A session of projected slides concluded the meeting at 17.40. The next autumn meeting is to be held Saturday 9th October 1993.

A visit was made to the Louvre on 9th October 1992, members meeting in front of the pyramid, in order to view the sundials in the collections. The most important are the fifty examples collected by Nicholas Landau, bequeathed by him in 1979, and by Mme Nicola Landau in 1986. Thirty Commission members attended.

The British Sundial Society receives a brief mention in the list of members, there is no mention of the BSS Bulletin although it has published some of the articles written by members of the Commission des Cadran Solaires. Evidently there is insufficient communication between the two organizations.

# DOMIFYING CIRCLES - ASTRONOMY AND ASTROLOGY

BY GRAHAM STAPLETON

In the article on Domifying Circles, (Bulletin 92.3., 2-4) it was described how a very few sundials have extra furniture to show the astrological significance of the sun's position as it passes through the six, out of twelve, celestial houses that are above the horizon. However, since it is possible to divide a sphere into twelve segments in any number of ways, it is not surprising that the system described is but one of fifteen invented by astrologers for their purposes. Yet the choice available for the diallist to use without great complication, is actually very small.

All of the systems employ a division of one of the great circles that constitute the celestial sphere, such as the equator, ecliptic, or horizon. The resultant house segments then having their axis about some diameter of the sphere, such as the line of the poles, or the zenith-nadir.

The oldest of these appears to have arisen around the first century BC, and is described by Claudius Ptolemy in his work *Tetrabiblos*. Comprising an equal twelvefold division of the ecliptic from the point where it intersects the eastern horizon, with the segments' axis aligned to the north and south poles of the ecliptic. That employed for the Tawstock dial, also the one most likely to be found on a planispheric astrolabe, is termed Regiomontanus; after the pseudonym of its inventor Johann Müller, (1436-76) Professor of Astronomy at Vienna. Dividing the celestial

equator equally twelvefold, the segments are made to converge upon the points north and south where the meridian crosses the horizon. Regiomontanus was much favoured by sixteenth century astrologers, such as the influential and mercurial William Lilly. To a dial-maker, then as now; it is almost the simplest to delineate, requiring no extra calculations.

The theory behind the twelve houses, is to give the astrologer an extra level of meaning to the planetary positions. By equating the first house with the first sign ie. Aries, and so on; the result is a daily revolving "zodiac" within the zodiac of the year. Only the latter six houses above the horizon can appear on a sundial; their traditional interpretations are as follows:

DOM. VII (Libra) partnerships, marriage, war, treaties, contracts, lawsuits. DOM. VIII (Scorpio) birth, death, regeneration, legacies, joint properties. DOM. IX (Sagittarius) philosophy, religion, law, travel, learning. DOM X (Capricorn) authority, honour, ambition, personal image, employers. DOM. XI (Aquarius) friends, groups, altruism, aspirations. DOM. XIII (Pisces) service, enemies, confinement, secrets, mysticism.

Anybody wishing to study this subject in more detail would do well to read Ralph William Holden's *The Elements of House Division*, published by L.N. Fowler 1977. (SBN 85243 354 9).

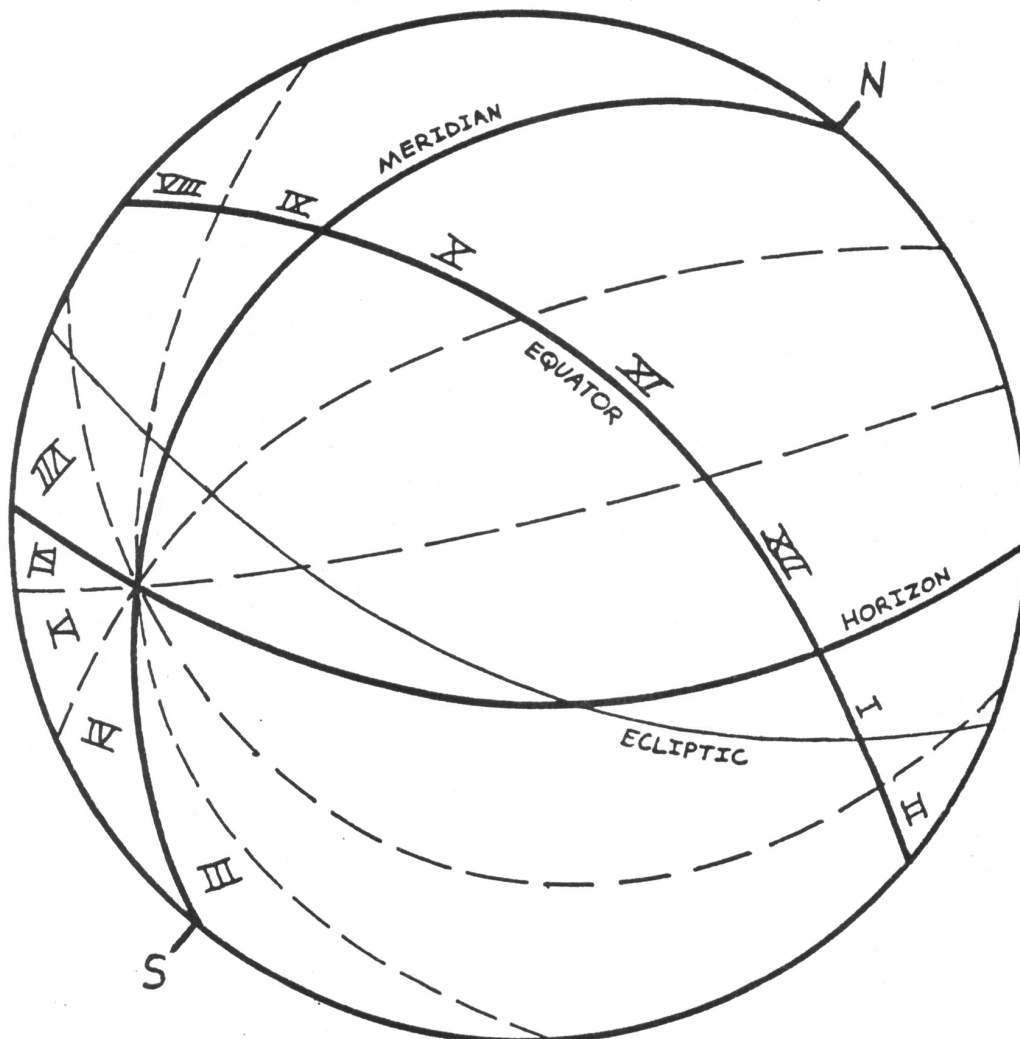

THE CELESTIAL SPHERE WITH REGIMONTANUS HOUSES

# SOME REFLECTIONS ON NEOLITHIC ASTRONOMY

BY RENE R.-J. ROHR, FRANCE

... and when we had reached the country of those barbaric people I had a feeling as if I had arrived in a different world.

(William van Ruysbroek, 1255)

The present study originates in a letter I received in 1972 from M. Thévenin, Professor of Strasbourg University, in charge of the *Circonscription for Prehistoric Antiquities in Alsace*. It contained an offprint of an article he had published<sup>1</sup> dealing with the discovery of a collection of scratched pebbles in a cavern near Villers-sous-Dampjoux (Doubs). The forty pebbles were flat and of the size of a hand, covered all over with various groups of lines scratched upon them by means of some hard implement, Fig 1. The author and his assistants

assigned these articles to the last phase of the Magdalénien period, somewhere between the Paleolithic and Neolithic Ages, approximately 8 to 10,000 years ago. I was asked if in my opinion, these scratched lines could possibly be marks of astronomic notations, for example solar or lunar calendar indications.

Years later I felt sorry for not having been able to give a positive answer at the time. For in the following decade I paid various visits to places like Altamira, les Eyzies, Lascaux and Stonehenge, and so my answer today would certainly have been more optimistic, see Fig 2.

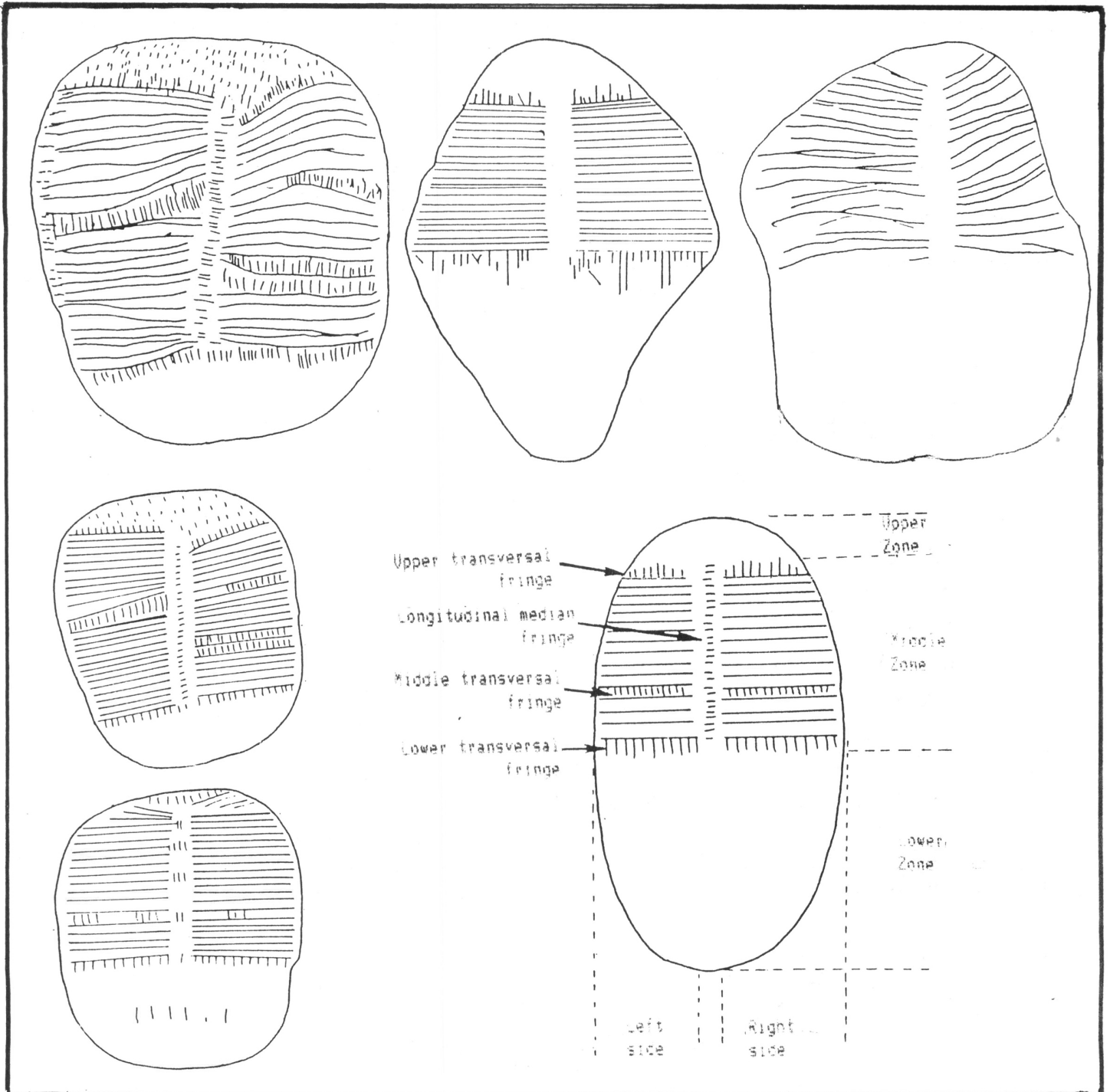

FIGURE 1: Scratched pebbles from a cavern near Villers-sous-Dampjoux, France. Drawings by Professor Thévenin.



FIGURE 2: Swimming stags, a drawing from a Lascaux cavern.

Today no one doubts that men of 10,000 years ago were not on an equal intellectual level with their present-day successors. Their cultural backwardness was a consequence of their historic surroundings, together with the normal evolution of human knowledge. No more than two centuries ago, similar conditions of life could be found in countries like Australia, Central Africa, Tierra del Fuego and others. They certainly had no conception of writing and reading, no names for large numerals; in other words their languages did not have suitable means to express values like the length of the year, or dimensions of any kind.

When notable propitious geographic or climatic situations occurred, a higher level of perception resulted as a natural phenomenon. Such cases arose when building of the Egyptian stepped pyramid of Saqqarah commenced in 4,300 BC, and about 4,000 years ago when the first laying out of the monument of Stonehenge was undertaken; when nearly thirty centuries ago Homer wrote his Epics and when a lifetime later Eratosthenes succeeded in measuring the size of the earth. All along the ages great thinkers have emerged, standing head and shoulders above the ordinary men and women of the time.

This discovery of the collection of scratched pebbles opened the door to reveal the existence of a sequence of archival treasures which are milleniums older. Just as surprises never fail to happen in series, a few months ago a French professional diver working along the Mediterranean coast found himself in one of the narrow creeks near Cassis (the "*calanque of Sormiou*"), and at a depth of 30 metres found himself in front of the entry to a cavern. Courageous enough to enter the narrow ascending gorge, he found himself emerging into a dry grotto after travelling about 130 metres, with its walls covered with paintings of men and animals in the same living attitudes as those of Lascaux or Altamire. The only real difference was that of age, radio-carbon 14 dating tests did not give 10, but 20,000 years!<sup>2</sup>

The lines drawn on the pebbles shown here must have meant as many markings as there were countable things. The numbers of different pebbles could thus be compared. It so happened that if one pebble could not bear all the marks for a larger number, a second one had to be adjoined to supplement the space, a fact that could not but make the task of interpretation by archeologists more difficult, if not impossible.

It was the opinion of Professor Thévenin that these annotations on the pebbles were certainly astronomic, and in all probability meant numbers of days, months or years. The circles of standing stones suggest that from time immemorial, the azimuth of the rising or setting sun has been observed in order to mark out the seasons and years. Its extreme excursion on Solstice days, combined with the marks on the pebbles soon demonstrated the true length of the year, even in the absence of a numbering system able to accommodate identification of individual large numbers. This measurement was easily repeated year by year and was, perhaps even a standard exercise for novices destined to be future priest-astronomers.

As to the moon, its varying phases never ceased to be the object of especial and constant observation. In prehistoric times the observation of the azimuth of its crossing the horizon line gave rise to further interesting facts. One is the result of the moon's orbit forming an angle of  $5.2^\circ$  with the apparent orbit of the sun, and that the intersection of the planes of the two orbits, the so-called nodes-line, rotates slowly around the ecliptic, completing one rotation in 18.62 years. Seen from the Northern hemisphere, this rotation is clockwise, whereas the movement of the moon and sun along the ecliptic is in the opposite direction. Once during each cycle it happens that when seen on a solstice day, the sun having attained its highest declination of  $23.5^\circ$ , the moon will also pass with a declination of  $5.2^\circ$  in its maximum celestial latitude, and in addition both will be in the same right ascension. This means that at this moment the moon's declination will be at its maximum excursion of  $28.7^\circ$ , being the sum of the two preceding angles, and its crossing of the horizon will be further northward than at any other point of the full cycle of 18.62 years. The phenomenon is given the name of *extreme moon set or rise*<sup>3</sup>, being regarded as the beginning of a new cycle. With certainty it would be especially noted in Stone Age times and recorded in cromlech alignments from the Hebridian Isles, through the whole of Europe, and on to the south of Asia. It would have been very strange if the monument of Stonehenge had been excepted, Fig 3.

As mentioned previously, the length of the year was soon found and verified. One might be allowed to think that the priest-astronomers, and possibly not them alone, would have an instinctive feeling that it would be convenient to group a number of passing years together in much the same way that we do in our centuries. Throughout history this practice has been constantly observed but in different ways, such as in Egypt or China, where the dynasties or the reigns of emperors were used, similarly in Rome, and even up to the days of colonisation in the Pacific Ocean, where most of the islands counted the years in generations. It appears that the custom of adopting similar cycles emerges wherever an embryonic culture begins to develop. If this system was adopted in Stone Age times, the duration of the adopted cycles would most certainly have been less than our one hundred years, which is a life-span seldom achieved even in our present era, but is particularly appropriate in our system of decimal numbers.

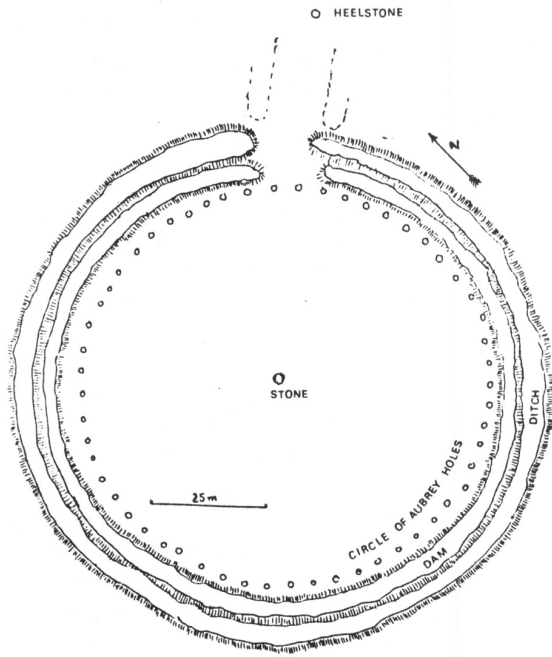

FIGURE 3: Possible layout of Stonehenge (original and first centuries).

However, these early people could not conveniently use the previously mentioned cycle of the extreme moon sets of 18.62 years, of which the beginning and end is easily observed, simply because there is no comparable comparison with any of the regular occurrences in human life. Moreover the number 18.62 could not be expressed by lines on a pebble, or by standing stones. If this number is multiplied by three, the result is 55.86, or very nearly 56, and this can be fitted into a primitive counting scheme. Additionally it does not exceed the probable span of men in those days if they died merely through old age.

It will be recollected that at Stonehenge there is the mysterious and oft-debated problem of the circle of the 56 so-called Aubrey holes. Is it possible that annually a heavy stone marker was moved with all due ceremony from one hole to the next, the whole celebration being a public annual calendar observation? It seems that this possibility has not been put forward previously.

The well-known American astronomer Gerald S Hawkins thinks the Aubrey holes may have been used as a means of forecasting eclipses of the sun or moon. Some of his colleagues object to this proposal on the grounds that Stone Age people would not have been able to carry out the arithmetical part of his solution. Similar proposals have been put forward, of which that from the mathematician Fred Hoyle may approach reality, namely that there was someone alive then who was the Newton of his age.

All over the world, even to our present time, people have never ceased to be interested in spectacular heavenly events, which in earlier times were often thought of as portending approaching calamity; for example the appearance of Halley's Comet in 1066 AD presaged the defeat of the English at the hands of William the Conqueror. Often the resulting fear of the populace has been a welcome opportunity to reinforce the authority of the priest-astronomers, a fact to which the innumerable standing stones bear silent witness today.

Renowned archeologists consider that at Stonehenge, the first of its important menhirs were erected less than five centuries later than the commencement of the religious or astronomical services held there; and that during these preliminary centuries, seriously matured astronomical considerations were tested for confirmation on the site, Fig 4.

Five centuries are half a millenium, during which many generations are born and die, and during which the communal memory can record and store much treasure in the form of experience and knowledge. Modern archeologists today struggle with the problem of finding out how, given an intelligent but little instructed populace, these could possibly be able to foretell eclipses.

By observing the rotation of the elements of a mechanical astrolabe clock, it easily demonstrates a way to arrive at a possible solution. The dial of the clock, Fig 5, is in fact the simplified diagram of an astrolabe; in other words it shows the stereographic projection of the rotating celestial sphere as seen and taught by Ptolemy, and as it appears to observers up to the present day. Its immovable dial goes from 1 to 24, its centre represents the earth around which are drawn the projected lines of the horizon, the twilights, the horizontal coordinates, etc. In front of this is the projection of the simplified starry



FIGURE 4: Stonehenge as seen today.



FIGURE 5: Astrolabic clock dial

heaven, reduced into the circles of the Zodiac and the ecliptic, all turning clockwise. On the surface of these plates are three independent hands which show the motions of the sun, moon and nodes. The starry heaven plate rotates once in 23 hours 54 minutes, whereas the sun, lagging behind the stars, needs 24 hours; thus its daily difference of about 4 minutes makes it travel round the ecliptic in 365.2422 days. The moon travels round the dial in 27.32 days, but as during this time the sun moves backwards each day by four minutes, it will take the moon 29.53 days to rejoin it, and this is the length of the lunar month. As already stated, these three elements, stars, sun and moon all turn clockwise at different speeds. The third hand is in the form of a dragon and figures the line of the nodes, is the intersection of the planes containing the orbits of the sun and the moon. The rotation of the node through the stars, and hence in relation to the plate, is opposite to that of the sun and moon, and is very slow, only one complete rotation in 18.62 years! Its very special significance is the fact that eclipses can only happen when sun, moon and earth are all placed in line, or very nearly so.

Now let us consider an open plane upon which a circle of some 100 metres is drawn around a stone marking its centre. It could be used in some way to find the times of possible eclipses just as the clock previously described. The days of the year could be marked into 365 parts separated by holes, these need not be of absolutely equal division. The role of the circle will be that of the ecliptic of the clock. Several rods are prepared and held in readiness, the lengths of each being different and representing the sun (S), the moon (M), and the days of an eclipse (E). On the first of these days an E and an S rod are placed in the sockets from which the operations will commence. The E rod will be left in its place while the S rod is daily moved into the next socket and a day-line scratched on a pebble to record this. In the same direction a moon-rod (M) will daily be moved forward from the E rod alternatively by 14 and 15 holes. After a period of time, a new eclipse will occur on a full or new moon day, and a new E rod inserted and everything will be operated as before.

Before long the observers will have learned the following facts:

1. The number of days marked on the pebble is on an average 178, the observed number differing occasionally by 14 days.
2. During eclipse periods, one, two, or three eclipses may occur at intervals of 14 days.
3. Some expected eclipses fail to happen.

After many years of observations the use of the perforated circle and its recording rods will become secondary and the marked pebbles alone will be sufficient for making forecasts.

In his famous book *Astronomicum Caesareum*, 1540, Petrus Apianus included illustrations of a number of instruments, these having a movable disc which the reader can turn, of which one of the best known (Fig 6) solves the problem on the same basis. The mathematician Fred Hoyle devised a similar solution, but although easy for a modern schoolboy, it possibly would not have been within the capability of a Neolithic star-seeker.

It must be kept in mind that the megalithic monuments, as well as the cavern paintings, should long ago have corrected the former opinion concerning the barbaric level of the Stone Age culture. Almost no one concerned themselves about what kind of people they were who built the enormous standing stone monuments, even though the Greek historian *Diodorus*, a contemporary of Augustus, towards the end of the first century BC noted the existence of an enormous island before the land of the Celts where the Hyperboreans worshipped a god who visited their temple every 19 years in order to correct their bearings of the starry heavens. It is beyond doubt that this is a reference to Stonehenge and to the 18.62 years of the extreme moon sets that had not escaped the assiduous observers of that time. The *Saros* cycle of 18 years and 11 days, after which all the eclipses repeat themselves at the identical intervals, would have been too complicated to have been discovered by pebble recording alone.<sup>4</sup> As for the other moon cycle of 19 years, discovered by the Greek *Meton* in the fifth century BC, and which *Diodorus* might possibly have thought of, after which the lunar phases occur in the same positions of the sun in the Zodiac, its discovery is inconceivable without the help of organized calendars.

In Britain the decoding of the megalithic monuments by scientists like Lockyer, Newnham, the Thoms and Hoyle; attain remarkable approaches towards what could possibly have been the reality. Yet, in respect of Stonehenge, it is Hawkins who deserves the crown. One of his books<sup>5</sup> has thoroughly cleared up the astronomic significance of the monument. It soon became a best-seller in spite of the violent opposition of many archeologists. For a time Hawkins found himself in a situation similar to that in which, half a century earlier, the meteorologist Alfred Wegener had put himself in publishing his book on continental drifts<sup>6</sup> that was fought with vigour by almost all the entire scientific world, until in the sixties the continental drifts became the foundation of geophysics. Alas, this was the thirty years after Wegener, in search of further proofs for his theory, froze to death in Greenland.

Likewise in search of proofs, Hawkins utilised the services of a mighty computer. Unfortunately computers





FIGURE 6: Astrological illustration with movable disc from Apian, *Astronomicum Caesareum*

only obey the orders they are given and are unable to formulate any ideas of their own.

Silent as ever in its stern majesty, isolated in time as well as in the scenic beauty of a Wagnerian opera, Stonehenge persists in holding its secrets, parting reluctantly sometimes with scraps which give rise to long periods of doubt and fierce arguments. The question remains, will a scholar ever appear, endowed with the indispensable gift which the youthful innocent student in Goethe's Faust tried to acquire, and succeed in crossing the limits of Time and, as did Ruysbroek, the Flemish Franciscan, those of Space, and spiritually emerge in strange and unexplored worlds. Will a man of the present ever be able to reach back into his beginnings to rediscover the knowledge lost in antiquity?

#### NOTES

1. A Thévenin, *Galets gravés aziliens de l'abri de Rochedane à Villers-sous-Dampjoux (Doubs)*, in "Congres préhistorique de France", XIX Session, Auvergne, 1969.
2. The 30 metre sinking of the cavern entry under the level of the sea could be explained in a tilting action of the west-alpine continental shelf where the melting of the ice on the northern half of the heavy layer of tertiary glaciation ice caused an important

decrease in the weight exerted and lead to an isostatic upheaval, whereas the southern half sank, similar to the action of a ship unloaded from one of its extreme parts only.

3. Most modern handbooks on astronomy no longer mention extreme moonsets. Nevertheless the declination curves for the moon extremes ( $\pm 28.7^\circ$ ) are drawn on a reflection sundial of 1644 in the Palazzo Spada in Rome; (see Rohr, "On Reflected Ceiling Dials", BSS *Bulletin* 90.3, October 1990).
4. Like the Saros-circle, the circle of Meton is seldom mentioned in modern astronomy books. Nevertheless a famous lunar eclipse which occurred on August 16th, 1617, was rediscovered in the fresco of recently restored, interesting, and perhaps unique sundial on an old church in Rufach (Alsace); this appeared again on 24th March 1978 after exactly 20 Saros-circles. (Rohr, "Das Rätsel der Franziskanersonnenuhr in Rufach" in *Schriften der Freunde alter Uhren*, XVI, 1977. An English translation of this article will be published in due course in the BSS *Bulletin*).
5. *Stonehenge Decoded*, 1965.
6. Alfred Wegener *Die Entstehung der Kontinents und Ozeans*, 1915.

---

## A WORD FROM THE EDITOR

Articles and letters from BSS members are welcomed. Our authors, sadly, are only rewarded by the prestige of appearing in an authoritative journal, now read throughout the world. Since most of the BSS funds are devoted to publishing the *Bulletin* there is nothing left to pay authors for their work. Authors may request additional complimentary copies of the *Bulletin* in which their work appears, or arrangements can be made for multiple copies at cost.

Letters are a particularly easy way of entering the field of authorship, but remember there may be brickbats if you are in error, so check your facts carefully. Some people spend a great deal of time looking for mistakes. If your letter grows too long, it may well become an article in its own right. Editors welcome concise letters which are to the point and informative. Controversy adds excitement and spice as long as it remains impersonal.

Submitted material should preferably be typed with double spacing between lines, on one side only of A4 sheets, with a generous space above and below to allow the Editor to exercise his skills. If this is not done, it means retyping, since the text gets so mangled with changes and additions that the person setting the text for printing has a most difficult task. Mathematical sections are particularly difficult if not set out clearly and well spaced, the presentation should be unambiguous so that the Editor also may understand it; normal conventions and symbols must be used. Illustrations - black and white photographs are the ideal, line diagrams and engravings - ok, less preferable are colour prints, especially if lacking contrast, but can be dealt with if there is nothing better. Drawings should be set out clearly and be of an adequate standard with fairly thick lines, poor drawings and smudgy photocopies require work to be done to make

them presentable - this has to be done by an unwilling Editor.

Illustrations should be on separate sheets, accompanied by clear captions, and not included in the article itself. The position of the figures and tables used should be clearly indicated within the text. References should be headed as such and listed in the order - surname, title of book or article, date and page numbers cited. Essential supplementary notes are best placed at the end of the text before the references, superscript numbers being placed appropriately in the text. It is customary to give acknowledgments to those who have given help in giving information and help to the author. In general, because of the excessive time delays which might result, proofs are not sent for checking.

The spelling style in the BSS Bulletin is based on the *New Collins Concise English Dictionary*, and *Hart's Rules for Compositors*. Archaic spelling is not encouraged since this makes difficult reading for some members.

At present there is a queue for material to appear, a newly submitted article may have to wait for a few months before space is available for its publication, letters should appear in the first available issue. The combined talents of the publication team can deal with French, Italian, German and Dutch texts, but the Editor prefers English if at all possible. Authors need not worry about perfection of literary style or punctuation, but accuracy of facts and figures is absolutely essential. With the increased sensitiveness in respect of copyright, do not use other people's material without first securing written permission, it is permissible to quote from a source, but better to be safe than sorry.

# VIETNAM VETERANS MEMORIAL

BY CHARLES K. AKED

**SUMMARY:** Helm Roberts, the designer of this magnificent memorial, is an Architect/Planner who works in Lexington, Kentucky. He was the successful competitor with his design for a Kentucky War Memorial which would include all the names of Kentuckians who died in the Vietnam War, plus those who were unaccounted for at the end of the conflict. The realisation of Mr. Robert's concept resulted in a unique sundial monument of great dignity and singularity of purpose, and one which is in dynamic equilibrium with the sun so that at the date of the death of each Kentuckian, the shadow of the gnomon touches his name in brief acknowledgement of the debt owed to him by his country.

## 1974:

The basic idea for the monument was realised as a model as long ago as 1974, the intention was to create a large sundial which would shadow the significant dates in history, however the project came to nothing because of financial limitations at the time. This was fortunate because it was destined for a much greater symbolic role in the future.

## NATIONAL COMPETITION

In early 1987 the Kentucky Vietnam Veterans Memorial Fund announced the details of a national competition for a suitable war memorial to honour those who fell in the Vietnam war. The design criteria stated:

"The monument should be distinctive yet dignified. It should not seek to imitate other monuments, yet it should evoke an emotional remembrance whilst being aesthetically authentic as a work of art. The monument should display the names of all Kentuckians who died in the Vietnam Conflict . . . or . . . still unaccounted for".

On the announcement of the competition, it occurred to Mr. Roberts that the idea of a sundial memorial might appeal to the Competition Committee and so he resuscitated his earlier ideas and submitted these. In June of 1987, his design was unanimously selected as the winner of the competition, although the Committee expressed concern that the design might not work in practice. Mr. Roberts was convinced that it could be done, and on discovering a computer program called ACEcalc used by astronomers for locating the position of heavenly bodies, he was enabled to construct a grid of parabolic sunlines to locate any shadow position on each specific day of the year on the actual sundial.

To give some idea of the enormity of the task, Fig 1 shows an artist's impression of the completed monument, which is approximately 89ft x 71ft. Figure 2 shows the foundation plans with over 800 concrete piers shown to support the granite slabs forming the surface of plaza of the sundial monument. The final layout of the foundation slab was made after observing Polaris to confirm the exact orientation of the plaza, a full-size temporary gnomon being set up to confirm the track of the shadow of the sun for 21st June, the summer solstice. This allows the locating of the 800 plus concrete supporting piers and the perimeter wall, a laser being used to ensure that the designed two per cent slope of the plaza was accurately maintained.

## GRANITE SLABS

The dimensions of each granite slabe was computed and

the maximum size of 12ft x 3ft dictated by the granite supplier's equipment. The AutoCAD computer program was used to prepare a drawing for each individual slab, the average size being 10ft x 3ft, with an average weight of 1500 pounds; the size of the joints between the slabs had to be taken into account, being set at  $\frac{5}{16}$  inch. Three hundred and twenty-seven granite slabs were prepared. The total weight of the granite slabs is 215 tons with the addition of those slabs used for the stone perimeter bench and five stones used as signs. When installed the slabs had to be given a uniform slope of 1 in 50 to give water drainage from the granite plaza, this of course requiring an adjustment to allow for the variation from the horizontal plane. It says much for the skill of the granite contractor and the computer calculations that every joint in the area of the huge plaza fell easily within the design limits. The Elberton Granite Finishing Corporation was responsible for the granite slabs supply and finish.

## VARIFICATION OF SHADOWS

To verify the various computer calculations, a scale model of the memorial was built to  $\frac{1}{24}$  of the actual dimensions, the shadow of the gnomon being observed on the actual site. These observations showed that some further effects had to be allowed for, eg. the penumbra effect on the shadow caused an apparent shortening because of the diameter of the sun. To be absolutely certain, a full scale model of the gnomon was made so that observed and calculated locations of shadows could be compared. It was found that an adjustment of one third of a degree was required and this was used to finalise the position of the names on the plaza. The rules of the competition stated that the names were to be cut into the slabs after the gnomon and granite slabs had been installed in the plaza, and after a year's observation of the gnomon's shadow to enable the names to be cut in the position thus determined empirically. However the proposed dedication date of November 1988 did not allow such empirical placing, and so the position of each name had to be calculated by the computer. Full size templates were prepared on a Houston Instrument DMP 51 plotter, the names being inscribed in the granite workshop and no fallen names were actually cut on site, although some other indications were necessarily incorporated after the slabs had been fixed in place.

## GNOMON CALCULATIONS

In autumn 1987, the gnomon was constructed from  $\frac{3}{16}$  in stainless steel plate, using dimensions calculated by AutoCAD. The gnomon and flagpoles were erected on a temporary plot above the permanent site. An official ground-breaking/gnomon dedication ceremony was held on 7th November 1987. This gnomon was moved from its temporary site to the permanent location of the plaza in July 1988. It is supported at three separate points so it can be adjusted for azimuth, height and tilt. The actual shadows were found to be within an inch or less of the computer calculations, and in late October the summer and winter solstice lines were cut into the plaza stone. Additional names were added for those Kentuckians killed but listed in the official National Record in another State. Another commemoration was added in the form of a marker to show where the shadow

continued on page 15

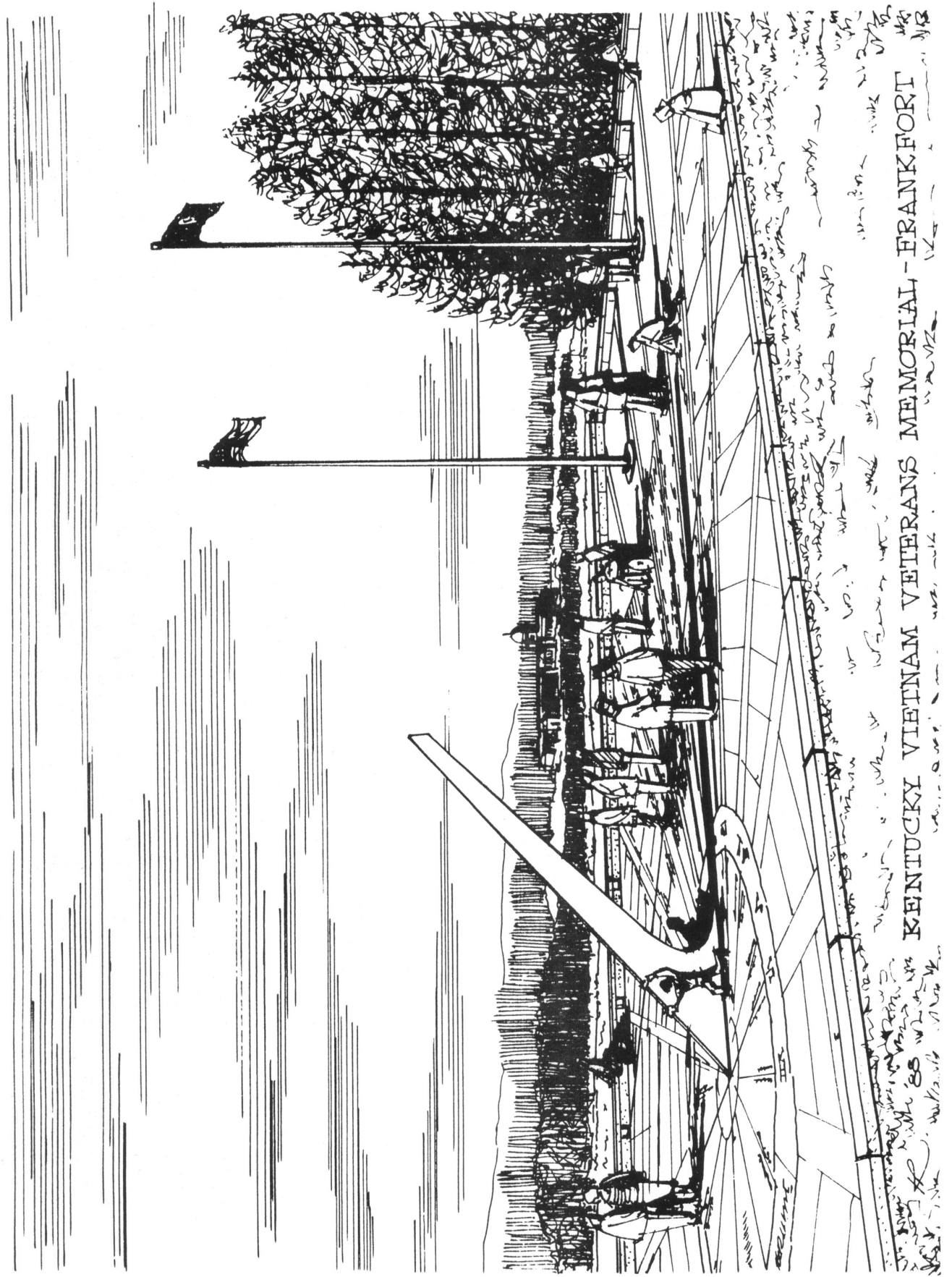

FIGURE 1: An artist's concept of the memorial drawn for the competition.

# Kentucky Vietnam Veterans Memorial

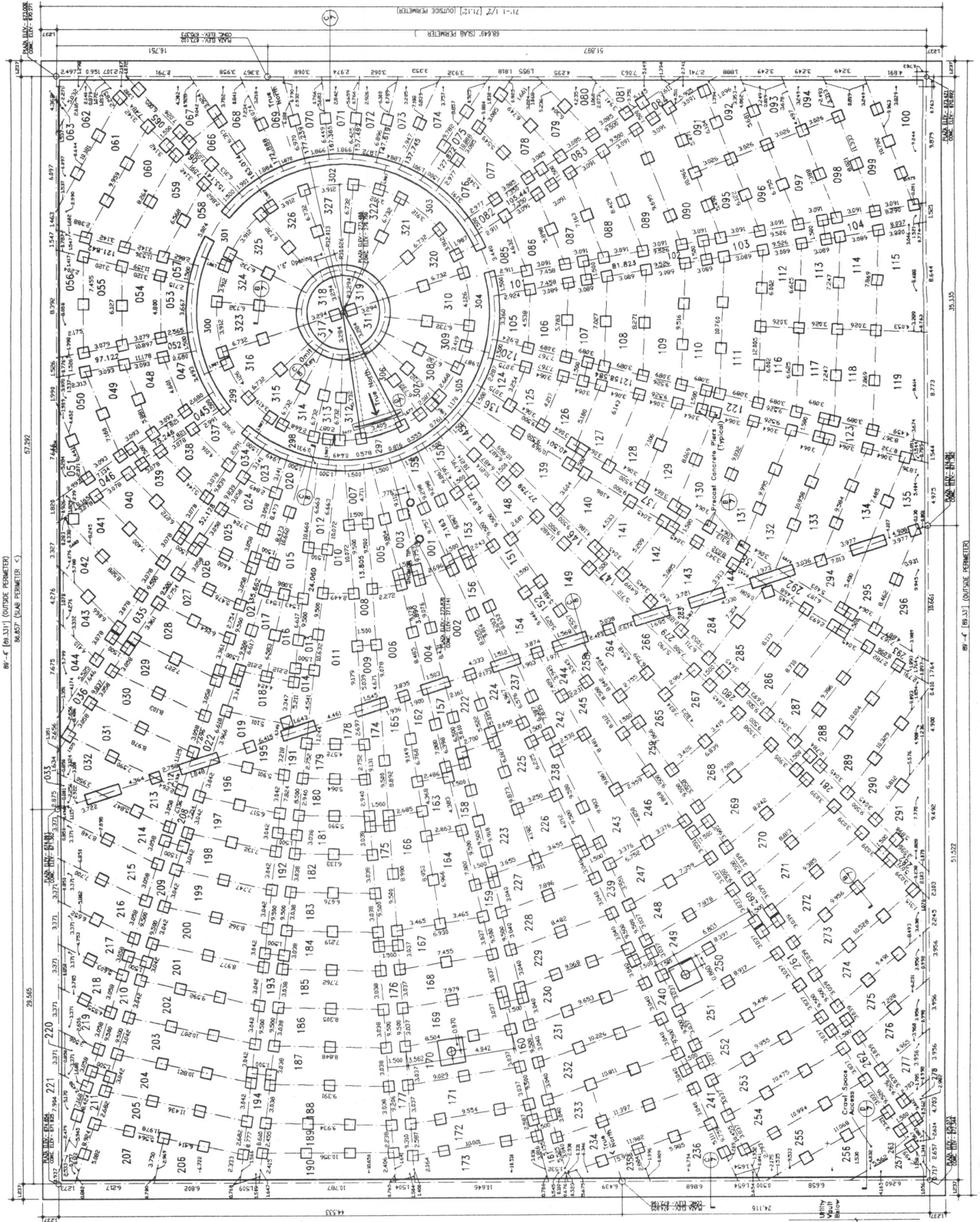
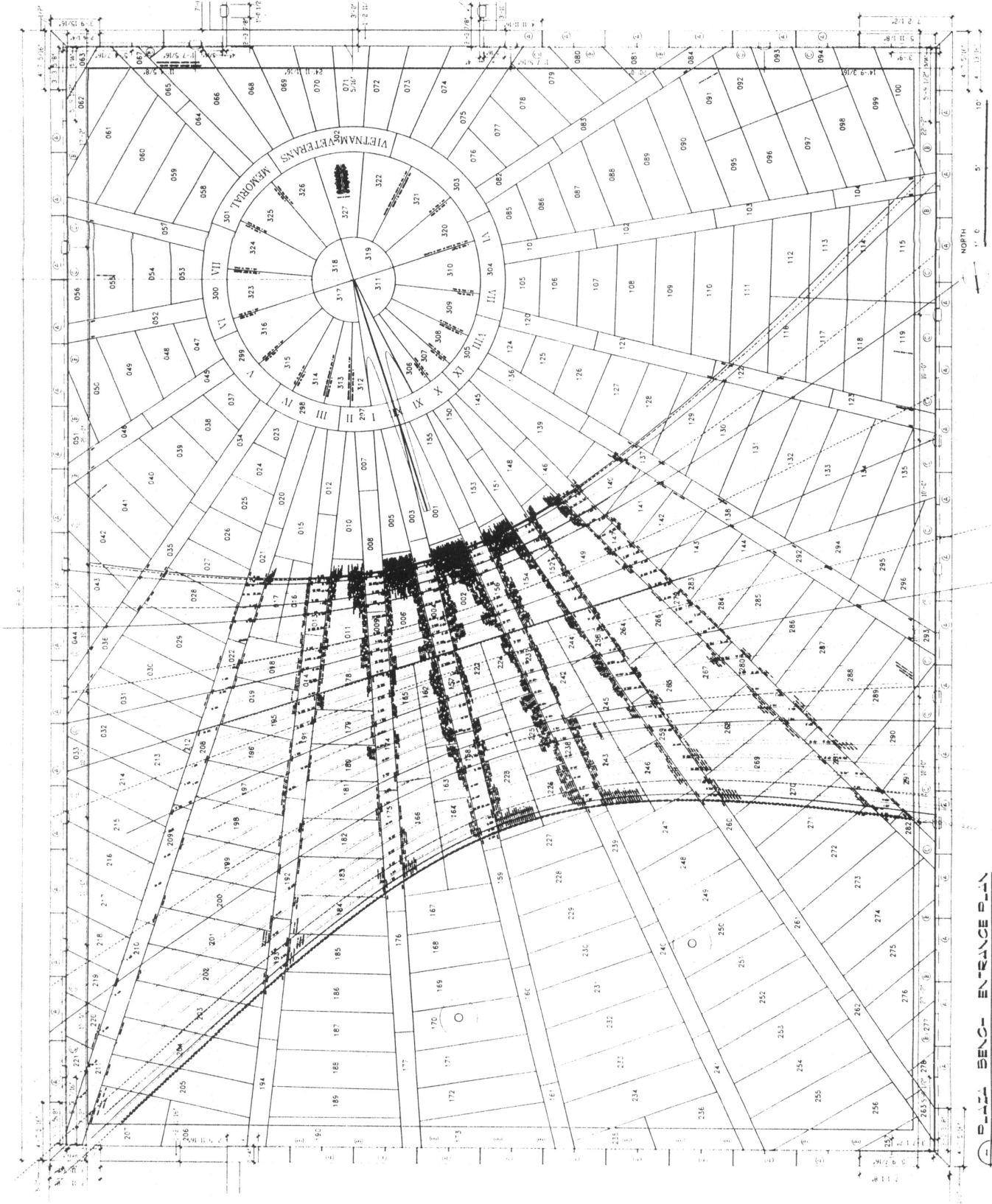

FIGURE 2: The foundation plan for the concrete pillars on which the granite slabs were later placed.

PLAZA/SLAB SETTING PLAN - (plus Sunlines) - KENTUCKY VIETNAM VETERANS MEMORIAL.....Frankfort, KY



PLAZA BENCH- ENTRANCE PLAN

FIGURE 3: The setting plan for the granite slabs.

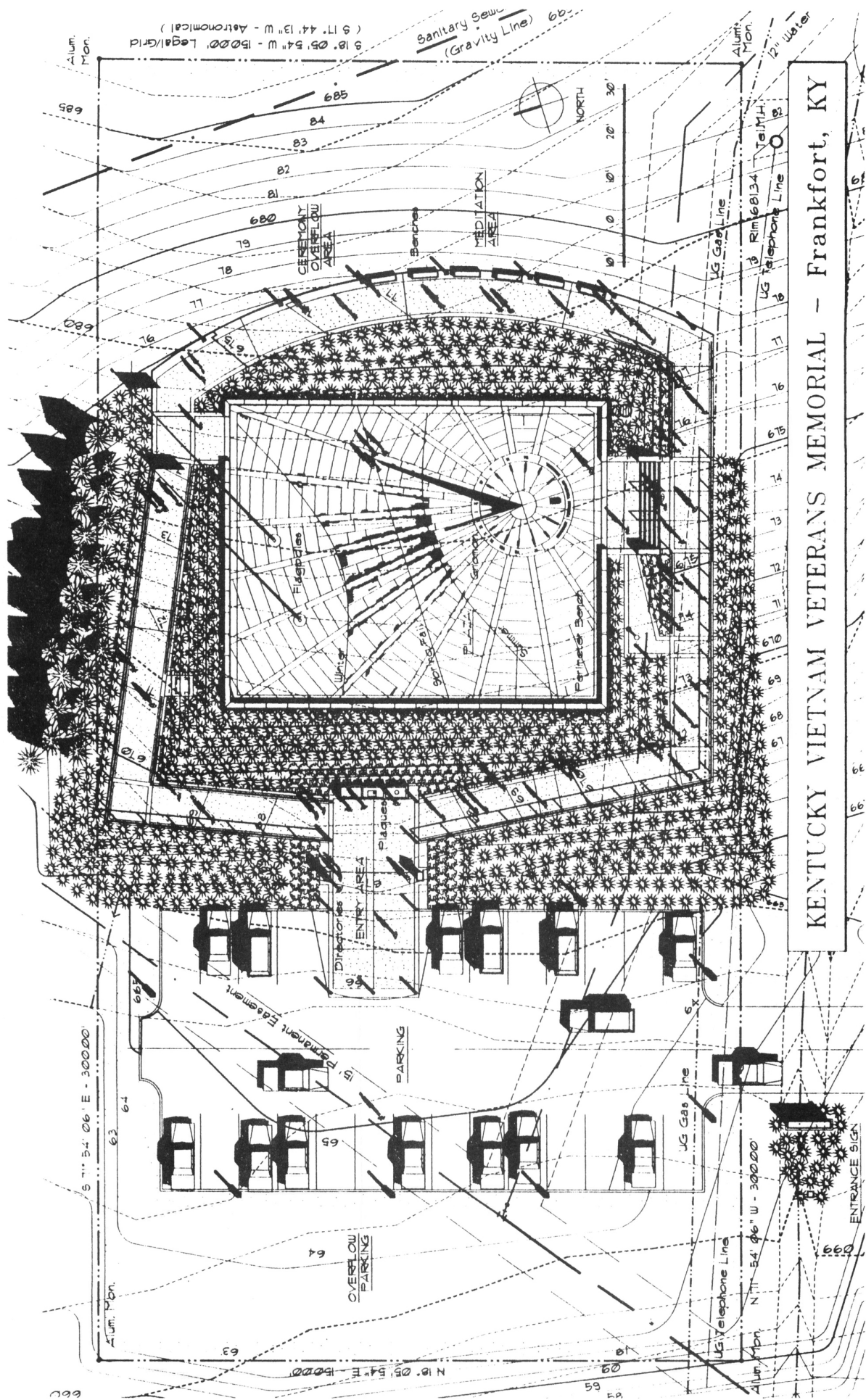

FIGURE 4: The overall plan of the memorial site.



FIGURE 5: A view of the Vietnam Veterans Memorial from the south-west.

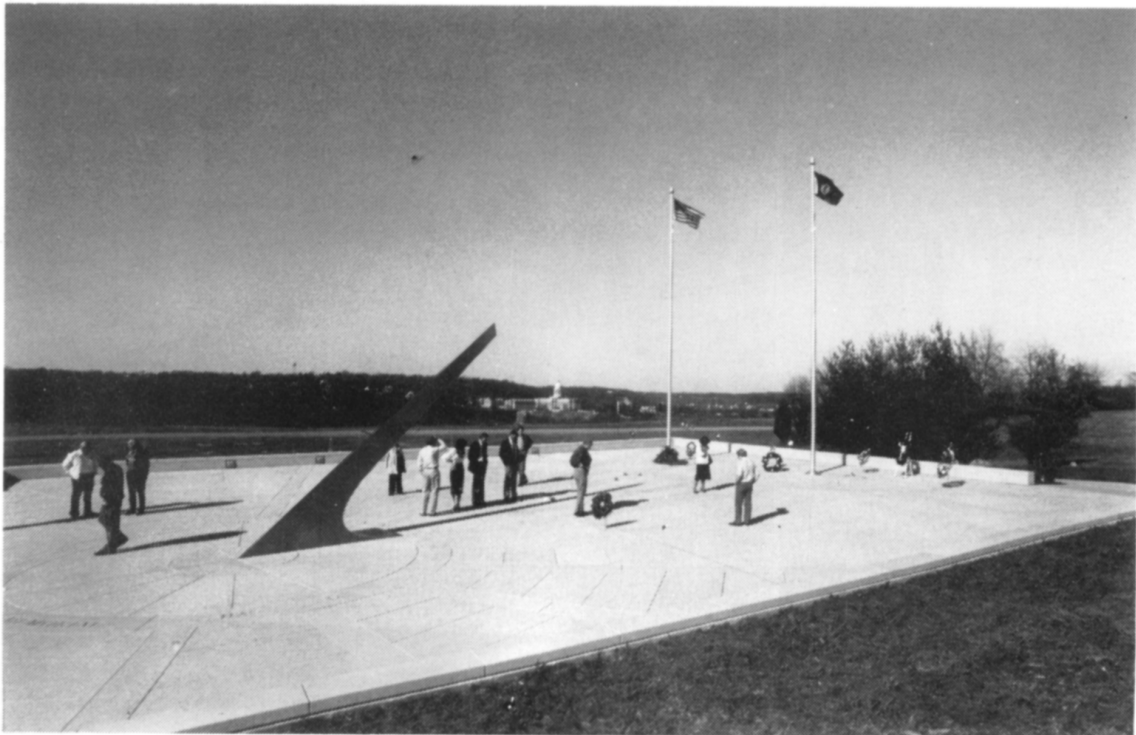

FIGURE 6: A view of the memorial from the south-east, note the wreaths laid by relatives of those honoured, and the respectful attitude of those on the site.



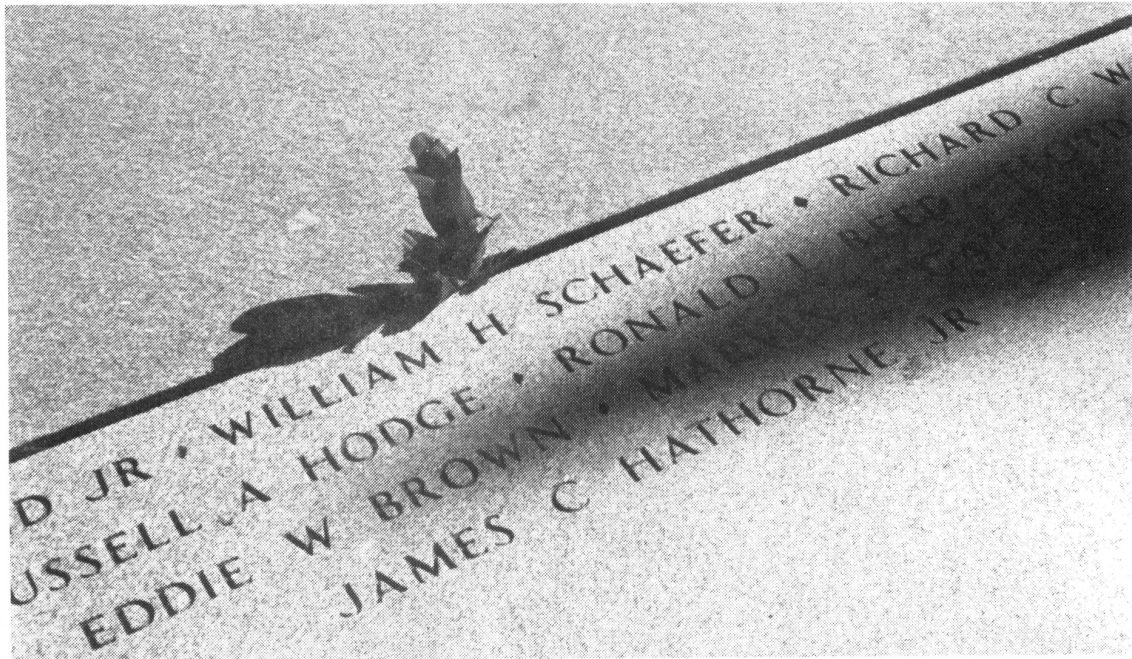

FIGURE 7: The name “EDDIE W BROWN” is shadowed in remembrance. Someone has placed a flower in the joint to accentuate the name “WILLIAM H SCHAEFER”.

falls at 11 minutes past 11 o'clock on 11th November, the width of the marker being exactly one minute to observe the traditional period of silence, it is of such length as to cover variations in the leap year cycle. In addition the shadow traverses a quotation from the New Testament: “Greater Love has no man than this, that a man lay down his life for a friend”.

**THE SUNDIAL**

The actual sundial is in the form of a circumscribed double circle centred on the base of the gnomon style, Roman numerals being engraved in the stone between the circular lines from VI in the morning to VII in the evening. Hour lines from the centre are extended to meet the inner circle at the figure location. On the South circular arc is engraved “Kentucky Vietnam Veterans Memorial”. The result is a very plain uncluttered dial austere complementing the vast memorial plaza with its sectors marked in years for 1962 to 1975, and the lines of the Summer and Winter Solstices, and the Spring and Autumn Equinoctial Line. All the indications on the plaza itself are of course indicated with the tip of the stainless steel gnomon, whereas the indications on the dial are by the shadow line of the style. There are twenty-three names inscribed behind the gnomon where its shadow never falls, these are the names of those missing in action. If the details are found at some future date, the appropriate name will be transferred to the indicating surface of the plaza, as has happened in the case of one man. Around the base of the gnomon is inscribed the words from Ecclesiastes 3:1-8, “For everything there is a season and a time for every matter under Heaven: a time to be born, a time to die . . . . a time for war and a time for peace”. The concern with all these small details show just how much care was lavished to make this a fitting memorial.

**DEDICATION**

On 12 November 1988, the Governor of Kentucky, Wallace G. Wilkinson carried out the dedication

ceremony on behalf of the Kentucky Vietnam Veterans Memorial Fund in front of over 7,000 people attending.

**FINAL NOTE**

The cost of the huge memorial was estimated at over one million dollars, of which the State of Kentucky provided 100,000 dollars, the rest came from private donations. This sum includes funding for the perpetual care of the monument and the special lighting running costs. It is sited near the State of Kentucky Library and Archives Building in Frankfort, within sight of the State Capitol. The writer of his article acknowledges his indebtedness to Mr. Helm Roberts in supplying the material background and the illustrations to be able to write this article, even to the extent of sending an actual model of this most impressive tour de force. Few of us would be able to produce such a masterpiece even if we had the opportunity to do so. It is a sublime indication of the eternal hope of mankind that those who have passed from us in trying to preserve decency in the world will be remembered by those who have benefitted from their sacrifices. How fitting that one of the most ancient of mankind's instruments can pay eternal tribute to those who laid down their lives in the Vietnam conflict, and in doing so, briefly touch upon each name so at that moment, the whole memorial stands for the memory of that single person alone. Often a visitor to the memorial will kneel to touch the name engraved in the granite as it is briefly shadowed, and is clearly deeply moved by the experience. Other visitors will halt their conversation when approaching a name touched by the shadow of the gnomon tip, and so every single name is remembered, quite unlike going to a military cemetery. Today the memorial is a shrine where often flowers and letters are deposited by those who have travelled there to remember their loved ones, or where people sit on the perimeter wall in quiet personal meditation.

A selection of photographs is added as a supplement so the reader may judge the visual impact of the memorial, all these were provided by Mr. Roberts.



FIGURE 8: The shadow of the tip of the gnomon gives poignant meaning to the memory of “JAMES C HATHORNE JR”.

## FURTHER PROGRESS ON THE SUNDIAL REGISTER

BY IAN WOOTTON BSS DEPUTY REGISTRAR

A year ago the BSS Sundial Registrar outlined the Society's ambitious project to record all the "significant" sundials in the British Isles. He proposed the setting up of a computer database to hold their essential details (Gordon Taylor, BSS Bulletin, 91.3). At the Edinburgh conference he recruited a number of members with their own computers to assist with the data input and by the time of the Cambridge meeting, the project was under way. This note is a progress report.

Information to be recorded is provided by a member filling up a "Fixed Dial Record" form. The form has evolved and is now in its second or third version. Completed forms are distributed by the registrar to one of the data input volunteers for transcription on to computer floppy disk. Data on the floppies are combined to produce the Sundial Register.

### PROGRESS WITH DATA INPUT

A number of minor difficulties emerged during the early weeks. For example, dimensions were almost always recorded in inches, although the register requires the use of millimetres. Similarly, national grid references were preferred to lat/long. So to avoid the continual use of calculators, conversion routines have been built into the input programs and various further improvements have been made to remedy other problems. The current programs are the fifth version issued.

At the start, between 1000 and 1500 records were available, most from the existing collections of members. Almost 1000 have now been transcribed to computer file and nearly all the remaining reports are with data input members.

### PROGRESS WITH THE COMPUTER FILE

The data base devised by Gordon Taylor holds the information as text files in the simplest possible format. This has the great advantage that the data is accessible in a variety of ways including by word processor. The disadvantage is that the data, for technical reasons, is spread across four separate files which require to be kept "in step" at all times. Further, if different selection of reporting modes are needed, special programs are required and must be written.

The BSS has recently obtained use of one of the new commercial database management systems which hold the information in a standard industry-compatible format. A decision has been taken to maintain the register in this new form in addition to the original. This will combine the benefits of the highly flexible Taylor format with the convenience built into the commercial database. Fortunately the two formats are interconvertible so that there is no question of having to repeat the data input stage.

There is an important further advantage. A considerable amount of effort has been invested in the register by a number of BSS members. The data is now held in two differing formats on two separate computers which are at different locations. The possibility that a local disaster could result in the loss of all data has now been removed!

At the time of writing (October 1992) the file holds 769 records, although it is known that there are instances where the same sundial has been entered more than once and file weeding will be needed. It is already obvious that the register reflects the particular interests of the main

contributors. The coverage across the country is extremely uneven (Table 1); no county except those listed has more than 20 dials while half of the counties in the British Isles are not represented by a single dial. Even my own county of Oxfordshire, rich in old buildings, reports a mere 14 dials.

TABLE 1

County	No. of dials recorded
Devon	147
Cumbria	73
Cornwall	69
Northumberland	48
Somerset	39
Cheshire	37
N Yorkshire	31
Essex	30
Suffolk	27
W Yorkshire	26
Cambridgeshire	25
Dorset	23
Gloucestershire	22
All the rest	172

### PROGRESS WITH VERIFICATION

A complicated operation like input of sundial data is bound to result in transcription errors. A verification operation has therefore been started. A separate group of members has been recruited to "proof read" the register listings against photocopies of the original reports. This stage has just started.

### FUTURE PROGRESS

Once the current backlog of records has been transcribed to computer file and the file has been verified (a matter of months rather than years), the project will have completed its initial phase. However, since it is thought that there may be as many as 10,000 significant sundials to record, it is clear that there is a considerable amount still to do. At the moment, three quarters of the records on file have been sent in by only 10 members so that it is clearly necessary for more of the membership to become involved in reporting. In particular, there are persistent rumours that some members have personal collections of dial records that they are reluctant to submit because the information is incomplete and does not measure up to the somewhat intimidating dial record form. This if true is a pity because we are very willing to include incomplete records, even just the type and location; at least this establishes the existence of the dial and means that it can be visited in the future and properly documented.

We are now in a position to offer a "Reporting Package" to any member who might be willing to help, say when going on holiday in the UK. The package will contain:- 1) A list of the dials on file (with details of type and location) in the county or counties of interest. 2) A copy of the guidelines. 3) Some blank forms.

The list will be of use to the member who wants to visit the dials already on record. It will also enable him or her to check whether a dial seen is already recorded, although it must be stated that some of the original reports are now becoming dated and an update report of a known dial is always useful.

# THE MERIDIANS OF ST SULPICE CHURCH, PARIS

G. CAMUS, P. DE DIVONNE, A. GOTTELAND AND B. TAILLEZ

Translated by Charles Aked

This instrument was remarkable at the time of its construction for its accuracy as well as for the beauty of the marbles of the obelisk. Actually the only gnomon which surpasses it in richness and grandeur is that of Bologna in Italy, - so wrote the barrister Auguste Nau in 1836.

The two celebrated meridians at St Sulpice, one conceived in 1727 by the horologist Henry Sully, and the other, conceived in 1743 by the astronomer Charles Le Monnier, illustrate the double role played by these meridians.

That of Sully's was to solve the problems of the measurement of Time posed in his age, that of Le Monnier's was used to make scientific observations of the movement of the Sun, and more particularly the obliquity of the ecliptic. It seems that Sully's meridian was the first to be provided for showing the time, whereas that of Le Monnier was the last to be utilised for astronomical observations.

## THE CHURCH OF SAINT SULPICE

The first stone of St Sulpice church was laid in 1646 by Anne of Austria. The work was commenced by the architect Gamard, then continued by the architects Louis Le Vau and Gittard, and terminated about 1727.

Languet de Gercy, Curate of the church from 1714 to 1748, had provided a solid wall for installing a meridian. This minister had for a long time sadly observed the continual uncertainty of the true time. This [meridian] was to traverse the transept. All precautions were taken with the parts which were to receive the meridian, in

particular the meridian portal was solidly erected and covered by an arch, borne on two great pillars; one of these pillars is placed, "not without design under the point of the Summer Solstice".

Although the previous church of Saint Sulpice was orientated along the cardinal points, the facades of the new church formed an angle of  $11^\circ$  with the east-west line. The meridian of the site thus cuts the transept obliquely, Fig 1.

## THE MERIDIAN OF THE HOROLOGIST HENRY SULLY - 1727

Henry Sully [1670-1728] was the apprentice of the celebrated London clockmaker Charles Gretton; he [Sully] made the first researches into the problems of Longitude, the results of which were known to, and valued by, Sir Isaac Newton. Friend of the celebrated horologist, Julien Le Roy, Sully executed a lever clock for measuring time at sea; with which he conducted experiments at Bordeaux and described in his "Description of a clock of a new invention".

## THE PROBLEMS OF TIME MEASUREMENT

With the perfecting and wide distribution of watches and clocks, the necessity increased of knowing the exact time and having all these indicate the same time. Many problems were thus posed, that of the difference between the official time given by the Sun, and that of watches and clocks; that of the exact time, its uniformity and its distribution. At first the official time in France was the true time given by the Sun, that of sundials. Louis XIV,

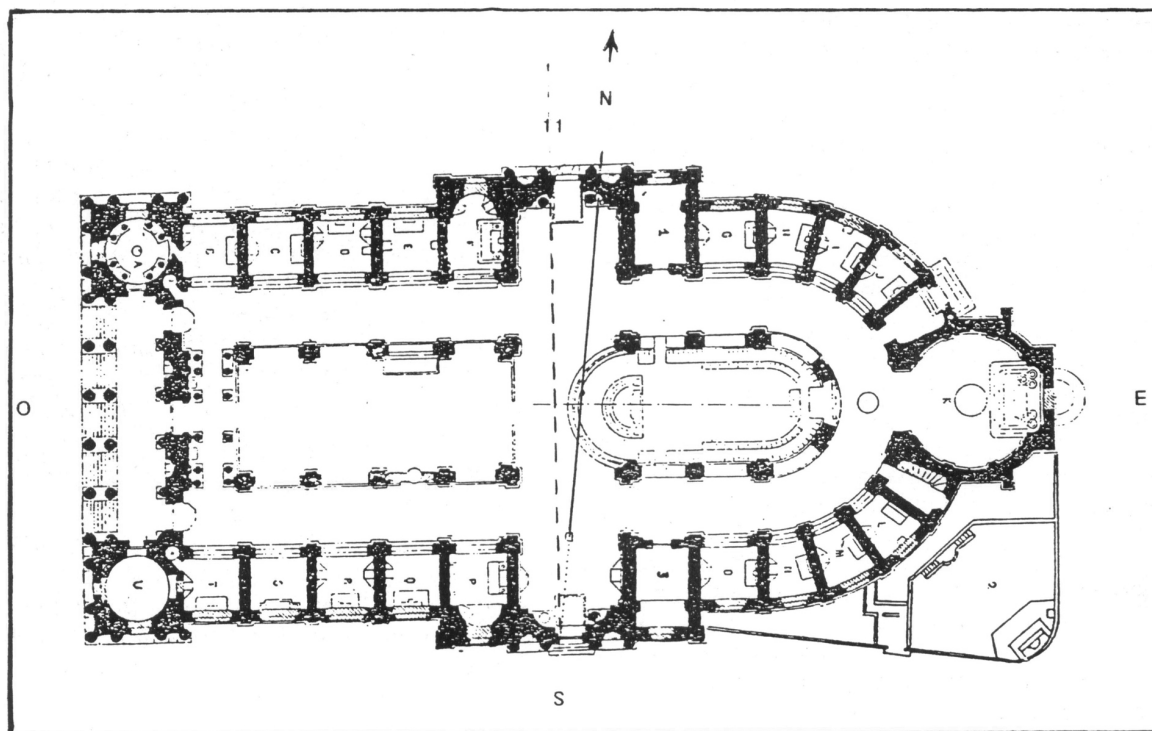

FIGURE 1 Plan of St Sulpice Church, Paris

the Sun-King, had been specific on 8 April 1641 when he decreed that “public clocks will be regulated to the course of the Sun”. This was an irregular time, moreover one which varied from one place to another; hence the maxim “See noon at his door”. Watches and clocks indicated a constant time in contrast to that of the Sun. The difference between the two times, mean and true, varied every day; true time is in advance by 16 minutes in November on mean time, and retarded by 14 minutes in February. On four days only do the two times correspond, 15th April, 13th June, 1st September, and 25th December. The varying difference between the two daily times [for the period of a year] is called “**The Equation of Time**”.

The clockmakers of the age were preoccupied by the standardisation of time; they were only too well aware that the bells of churches and belfries often sounded the hours in a disorganized fashion; and they wanted everyone to know the exact time of true noon, at the same time counselling them to regulate watches and clocks on the meridians and in constructing these “on the floor or tiles of a room, on the wall of a house or garden”. Jaques Cassini II wrote “There is a meridian in all the castles where the King passes”. They can be found in the castles at Vaux-le-Vicomte, Malesherbes, Versailles . . . Astronomers installed them in their observatories for ascertaining the exact time of their astronomical observations.

Sully wrote, in his *Regle artificielle du temps*, a chapter entitled “Of the way of using apparent and mean time for the regulation of clocks and watches”. A great meridian was his method of solving the problems of time determination in Paris. He wrote: *The time of noon would be given by the luminous disc and announced to all by means of sound*, and also: *For many years I have thought of some practical means for knowing the true time of the Sun with exactness every day; and which would be reported to all those instruments which serve for the measurement of time, and above all Public Clocks. And again, It is inconvenient as well as bizarre, that in a Town such as Paris, one is subject to a great discordance and uncertainty of true time of day, such has always been the case up to the present. It does not appear easy to provide an efficacious remedy to this general inconvenience; which can be generally agreed, so that all the public can profit at the same time.*

He himself wished the announcement of noon to all Paris: *By a signal of which the method was already conceived and finalised, a uniformity in time for all the Town would be reached, on the presumption that each and every one would be pleased to conform to it.* But what would this signal be? It was necessary to wait until 1784 for Paris to have an acoustic meridian at the Palais Royal. [In the form of a noon cannon fired by the sun].

#### OTHER MERIDIANS FOR TIME MEASUREMENT

At the time Sully conceived his meridian, the astronomer Grandjean de Fouchy, who was also a member of the Society of Arts, installed a studded meridian in the floor of a room of the Petit-Luxembourg Palace, the home of the Count of Clermont, and incorporated the 8-curve of mean time, which he had invented. A similar meridian exists today in a saloon of the Hotel de Bauffremont in Paris.

Following these, a number of large horizontal meridians for indicating the instant of noon were

installed in France, where six meridians above all were used for the regulation of clocks, in the church of Sainte-Madeleine de Besançon in 1755, Bourges cathedral in 1757, in the Abbey of Saint-Pierre-sur-Dives in 1776, Nevers cathedral in 1781, in that of Narbonne in 1786, and finally in the church of L’Ancient Hôpital del Tonnerre in 1789, where Camille Ferrouillat constructed a meridian with an analemma, which would be the last French meridian.

These are numerous in Italy in churches and convents, citing those examples of the Convent of Saint Joseph at Brescia in 1742, the Palais de la Raison at Bergame in 1748; the Chartreuse de Saint-Martin at Naples in 1778; of the Saint Maria Barracano and of the convent Saint Michele in Bosco at Bologna in 1776, of the chateau of Carraresi at Padua in 1778; of the Dome of Milan in 1786; the Palace of Justice of Padua in 1787, and the cathedral of Palermo in 1801; of the Palais Taverna, Rome in 1829; of the Galuzzi Convent at Florence in 1750; the church San-Nicolo at Catane in 1841; old ones were re-established with curves of eight at the Academia des “Fisiocritici” at Sienna in 1848; at the Palais de la Raison de Bergame in 1858. The last meridian to be laid down was that at the church of San Giorgio de Modica in 1895.

Others were constructed at El Escorial, Spain, in 1775, in the Hall of the Ambassadors at Malta in 1775; in the Society of Jesuits of Porrentruy in Switzerland in 1812; in the cloister of Durham Cathedral in England. In Belgium, by a decree of Leopold I in 1836, at the time of the development of the railways, these had been requested by the astronomer Adolphe Quetelet, who installed some meridians in Brussels, Anvers, Terremonde, Bruges and Ostend.

#### DESCRIPTION OF SULLY’S MERIDIAN

The meridian was described by Sully, Le Monnier and Le Lande.

Sully described his meridian in the “*Mercure de France*” of July 1728. Le Monnier gave a description in his “*Mémoire à l’Academic des Sciences*” of 1743, and Lalande in the “*Encyclopédie Méthodique*” of 1784. Fig 2 being drawn from his description.

*The plaque which carried the aperture of one inch diameter has the form of a gilt sun and it is found within the stained glass window on the meridian at a height of 24.363 metres. The sun’s rays pass through this circular opening of one inch diameter cut in a brass plate, solidly attached on the west side of the meridional window of the crossing at a height of 75 feet, forming an oval image of about 10½ inches long and 9½ inches wide at the Summer Solstice; which image is augmented in length and width for all days up to the Winter Solstice, and returns to diminish in size in the same manner, so wrote Le Monnier. (See Figure 2)*

#### THE MERIDIAN DESCRIBED BY A.G. BOUCHER D’ARGIS

A.G. Boucher D’Argis in *Variétés historiques* of 1752 gives more precise details plus some less well known: (See Figure 3)

The vertical point is marked in copper inlaid in a large stone under the width of the meridional door. From this point dividing two columns which extend the meridian and carry the inscriptions, left “division of the line in

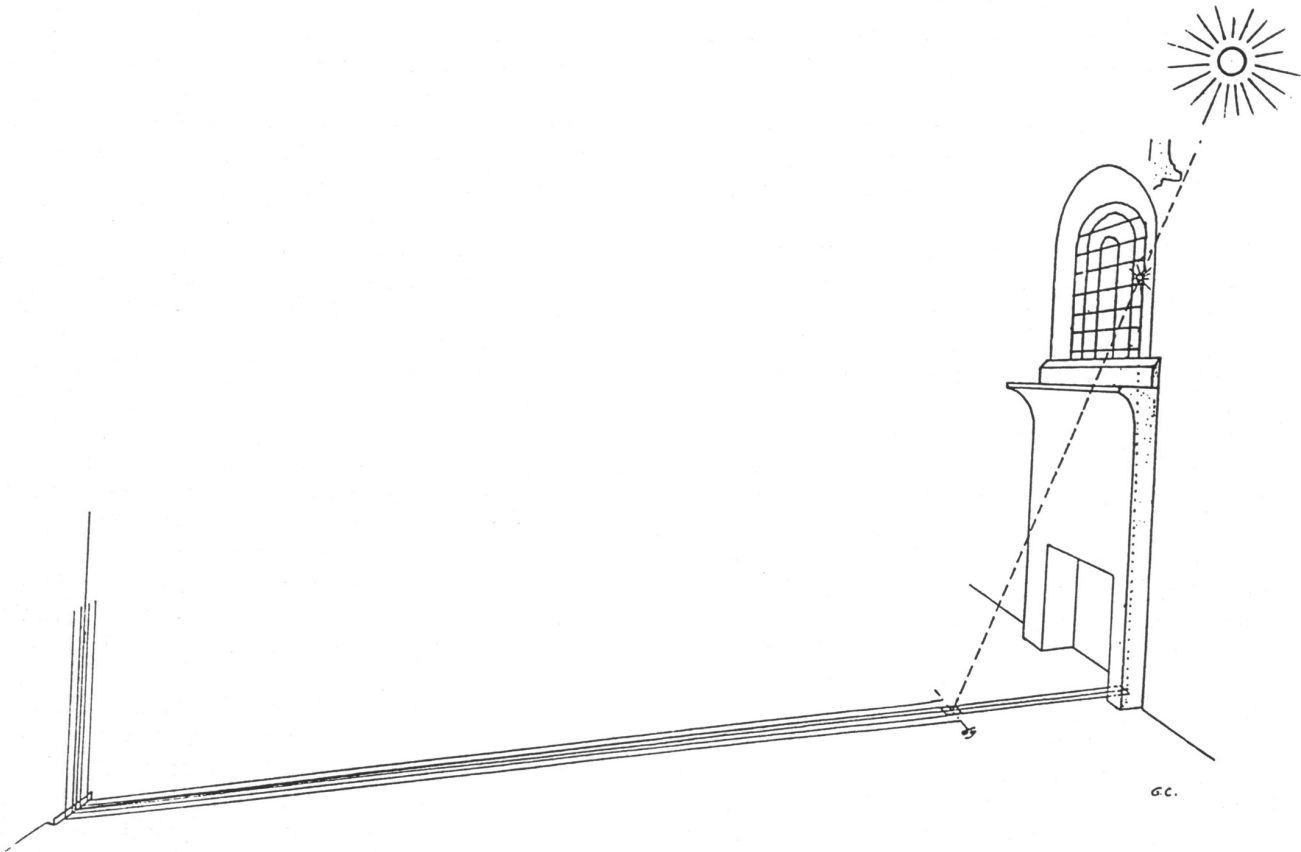

FIGURE 2: Diagram illustrating the meridian of Henry Sully

<p>The hours and minutes of the setting of the sun at five minute intervals.</p>	
<p>The place of the sun in the ecliptic with ascending signs, figures, names and degrees.</p>	
<p>Degrees of declination of the sun, to the north of the meridional on one side of the equator and up to the other tropic.</p>	
<p>Tangents to the thousandth part of the radian.</p>	<p>69 Degrees and minutes of the distance of the zenith to the Tropic of Cancer.</p>
<p>The place of the sun in the ecliptic with descending signs, figures, names and degrees.</p>	<p>Division of the line in thousandths part of the vertical height.</p>
<p>The hours and minutes of the rising of the sun in five minute intervals.</p>	

FIGURE 3: Tabular description of Sully's meridian by A.G. Boucher-D'Argis

thousandths parts of the vertical height” and right “degrees and minutes of the distance of the Zenith to the Tropic of Cancer” and the corresponding figures. Note that the meridian of the Observatory carries the inscriptions “degrees and minutes of the meridian height” and “tangents of the distance of the sun to the zenith”.

The point of the Summer solstice carries the inscription: “Summer Solstice of 21 June 1728”, the figure of the sun’s image at this date and the sign of Cancer. After leaving the Summer solstice, the meridian line is surrounded on each side by two more columns, making six in all.

The transept of the church being too small (to accommodate the meridian), the image of the winter solstice is projected on the northern wall which is not quite 180 feet away; at the beginning of November, the meridian becomes a vertical line on the north transept wall. “Although this line is 176 feet upon the floor of the church, which is the length of the transept, it is not however sufficient to receive the rays of the Sun near the Winter Solstice; it would have been necessary to have had a length of more than 240 feet”, see Fig 4.

The death of Sully [in 1728 at the early age of 48] marked the end of the work on the meridian, it is not known exactly what he had begun to trace. It seems that the meridian line was intended to cross the transept without running to the choir which was not finished until 1727.

#### THE REMAINS OF SULLY’S MERIDIAN

Some traces of Sully’s meridian are still visible, parallel to

those of Le Monnier, at a distance of 45 cm, one line is particularly visible in the north transept porch, where at 1.5 m three parallel lines at distances of ten cm are engraved in the floor, also some inscriptions: the figures “200” and “100”, Fig 5. The figure 200 must correspond to the two-thousandth part of the height of the meridian. This being of 75 feet, or 24.363 metres, the thousandth of the height, the figure 100 must be found at the foot of the gnomon in the part which actually constitutes the revolving door near the church, all trace of the meridian line having disappeared at this spot.

Sadly Henry Sully died on 13 October 1728, aged only forty-eight years. He did not have the pleasure of seeing this meridian line in its perfection; but it is all traced and he has, it is said, left all the necessary instructions on this subject, wrote Piganiol De La Force. Sully was interred in the church. His Illustrious Pastor, the Curate of Saint Sulpice . . . buried him in the church, close by the Sanctuary Doors of the Great Altar and a little to the West of the same meridian, on which he had traced the degrees and the Signs, only a few days before his death, wrote Julian Le Roy.

The same year, 1728, Jacques Cassini II took over the Paris Observatory and the meridian which his father Jean-Dominique Cassini I had installed 1680-2. The exact time was given henceforth by the clock sounding seconds, constructed by Fieffe, and installed close to the meridian line which was regulated each day by the meridional passage of the sun.

Fifteen years later, Charles Le Monnier, took over Sully’s meridian line. But he transformed it and utilised it for his own astronomical observations.

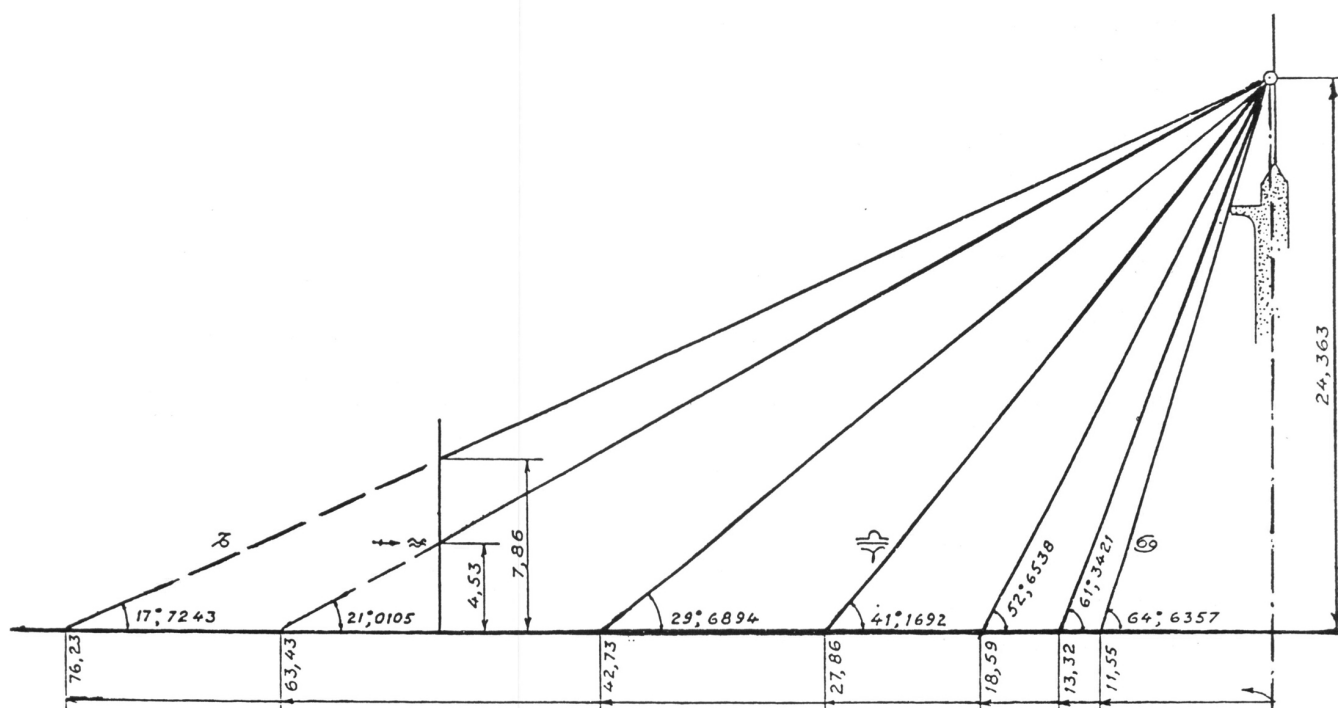

FIGURE 4: The principal dimensions of Sully’s meridian

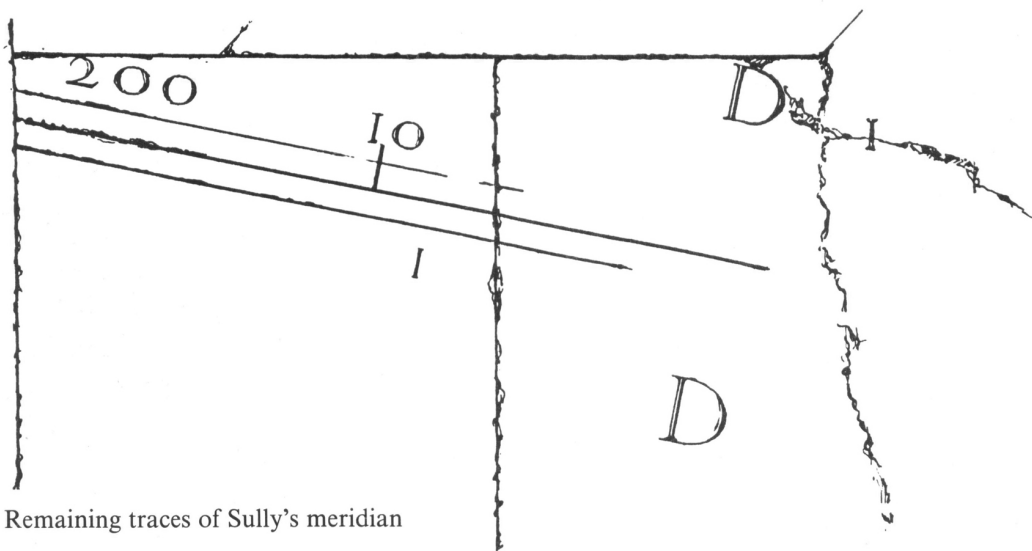

FIGURE 5: Remaining traces of Sully's meridian

## THE MERIDIAN OF PIERRE CHARLES LE MONNIER IN 1743

### THE ASTRONOMER PIERRE CHARLES LE MONNIER

At the age of 16 years, Pierre Charles Le Monnier [1715-1799] observed the opposition of Saturn; at 20 years he presented a new figure of the Moon with the description of its markings and, at 21 years, 23 April 1736, he was received into the Academy of Sciences as assistant geometrician. He accompanied Maupertuis on his scientific expedition to the Polar Circle and there put in use Flamsteed's method which allowed great accuracy in the tables of the Sun and in the position of the stars.

In 1741 he established a new catalogue of zodiacal stars and a new zodiac map; he first determined the changes of the refractions in winter and summer; he undertook the correction of the stars and accurately determined the height of the pole at Paris; he introduced transit instruments in France and observed the retrograde movement of a comet which had then appeared.

In one of his biographies it is stated that he made, 1753, a meridian in the chateau of Bellevue, occupied by the Marquise de Pompadour. For this meridian he received a sum of 15,000 livres from the king, which he expended on instruments purchased in London.

He became the King's Lecturer in Philosophy, member of the Royal Society of London, member of the Berlin Academy, teacher at the College of France, astronomer to the French Navy, in 1752 and 1765 he was Director of the Academy of Sciences; on 18 Frimaire year 4 [9 December 1795] he was elected Member of the First Class of the Institute in the Astronomical section. He wrote numerous works.

### THE ASTRONOMICAL PROBLEMS OF THE AGE

Up to the 16th century the meridian lines had been used for determining the Easter calendar. The Dominican savant Egnazio Danti, consulted by Pope Gregory XIII, constructed meridians at Florence in 1574, and at Bologna in 1575, for determining the precise moment of the Equinox. The astronomer Maraldi had constructed a meridian in the Chartreux convent in Rome in 1701, at the request of Pope Clement VI, in order to restudy the Gregorian calendar.

Another absorbing problem of the astronomers of the age was the diminution of the obliquity of the ecliptic since the measurements which Pytheas had made in Marseilles about 350 BC; the astronomer Gassendi also

made use of gnomons and installed a temporary meridian at Marseille for the summer solstice of 1636.

Jean-Dominique Cassini I, thanks to the meridian which he had installed in the church of St Peter in Bologna, observed an obliquity of  $23^{\circ} 28' 47''$  and studied the apparent variation in the diameter of the Sun, he also wanted to be able to reform the theory of the sun and to determine the amount of the refractions.

When J D Cassini was called by Colbert, at the direction of the Royal Observatory of Paris, he installed a meridian like that at Bologna, from 1680 to 1682 on the second floor, in the actual meridian room, with the help of astronomers Picard and La Hire, where he continued to study, in particular, the obliquity of the ecliptic. This meridian became the meridian of Paris and of France. In 1702, the astronomers Maraldi and Bianchini constructed a beautiful meridian for studying the Easter Calendar anew in the church of St Mary of the Angels in Rome. In 1728, the meridian of JD Cassini I was taken over by his son, Jacques Cassini II and carefully refurbished. The son of the latter, Cassini de Thury III had written: *The first use that my father made of the newly traced meridian, was to determine the obliquity of the Ecliptic which he found in 1730 to be  $23^{\circ} 28' 20''$* . He compared his observations to that of his father in 1671 and found a diminution of 27 seconds in 60 years, or 45 seconds per century [the accepted modern value is  $46.85''$ ].

At the same time as him, other astronomers were also studying the ecliptic on a meridian, some in churches, some in observatories, Ximenes in Florence cathedral about 1750; in observatories: Lelli and Zanetti at Bologna in 1741, Verbiest in Pekin in 1761, Hell at Eger in Hungary in 1776, Casselli at Naples in 1791.

### WHAT WERE THE OBJECTIVES OF LE MONNIER?

These are given in the *Mercure de France* of January 1744: The principal difficulties of resolving or reducing the following problems:

1. Of knowing the best method of determining the moment of the equinox and making precise observations:
2. Of verifying that the obliquity of the equinox is diminishing, and if this diminution is real, of making sure that the diminution is as rapid as is supposed:
3. Observing if it is true that at each half-revolution of



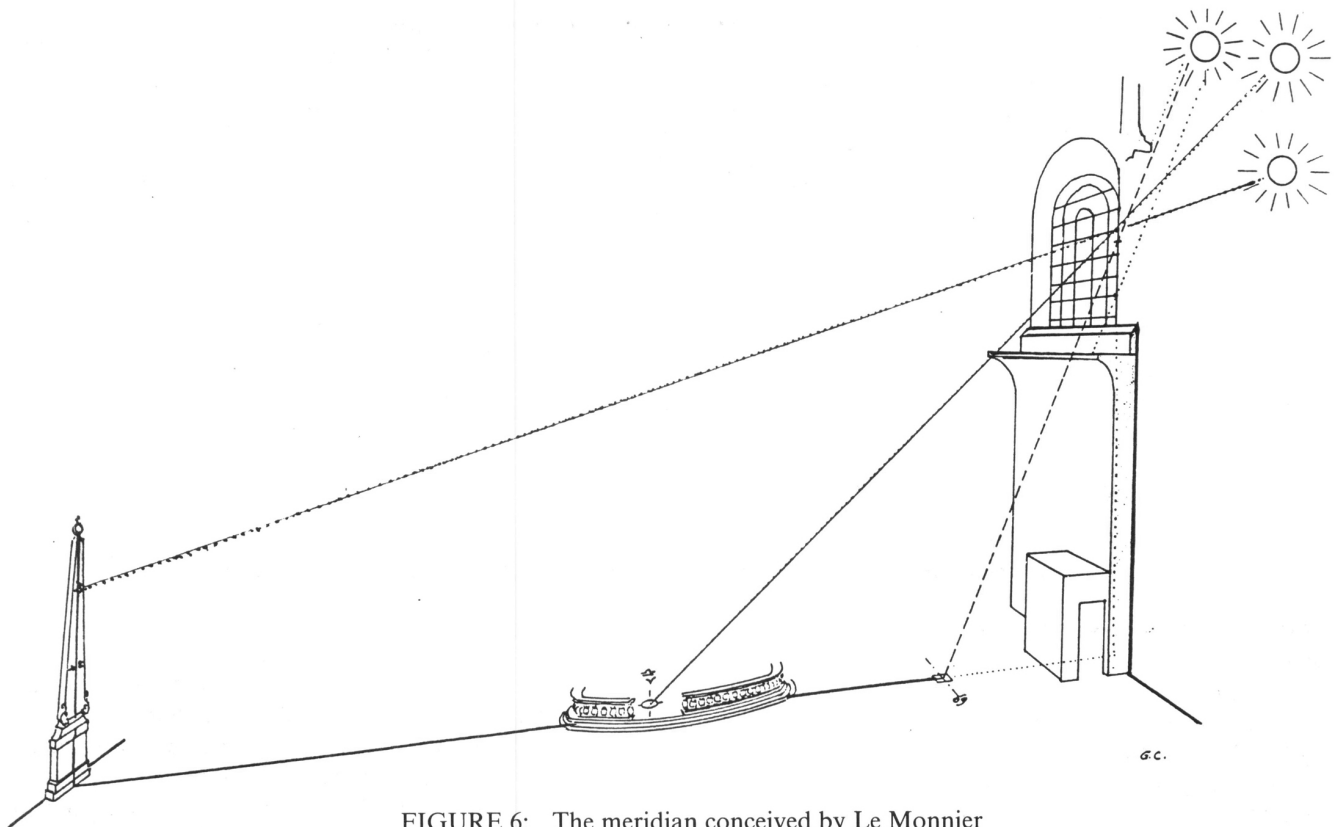

FIGURE 6: The meridian conceived by Le Monnier

the nodes, the Moon does not cause a detectable imbalance or nutation in the Axis of the earth; and finally to distinguish the variations in refraction that the variations of cold and heat can produce in the heights of the Sun at the Winter Solstice.

#### THE MERIDIAN CONCEIVED BY LE MONNIER

The works carried out by Le Monnier in order to transform Sully's meridian are described in the Memoires of the Academy in 1743.

It was traced by Claude Langlois, Engineer of the Louvre Galleries, who had already made the meridians for Jacques Cassini at the Observatory [Paris] and at the Pont au Change, a new meridian of 18 pouces [inches, about 0.49m but in actuality 0.45m] to the West of that of Sully, Fig 6.

The leaded glass window of the meridional transept was entirely obstructed by metal plates, to attenuate the ambient light and make the sun's spot more luminous [improve the contrast]. The first aperture is installed at 80 feet [25.98m], replacing the metal plaque in the likeness of the sun installed by Sully. Le Monnier fixed a new plaque in the thickness of the wall which did not exceed an opening of an inch in diameter [actually 27mm] presented to the rays of the Sun, which rendered it less subject to expansion in heat and contraction in cold.

A second aperture was installed in 1745 at a height of 75ft [24.363m] for the Summer Solstice because Le Monnier had discovered that the entablature of the lower external cornice intercepted the sun's rays and prevented these reaching the meridian line for many days before and after [the summer solstice]. From the first day of June to the last day of July, the sun's rays are constrained by the exterior obstruction and the aperture cannot project an image upon the meridian line, see Figs 7 and 8.

Le Monnier also improved the observation by making use of a convergent lens. He had installed a second opening 5 feet lower than the first, on the side towards the inside the church, in the same plane of the meridian and there adjusted and sealed a glass objective of 80 feet focal length and 4 inches diameter [108 mm], with its optical axis located in the plane of the meridian.

La Lande saw the objective in a frame: The objective which constitutes this new opening is about 4 inches in diameter, and is enclosed in a box or kind of frame which can be closed with a key and not opened except in order to make the Summer Solstice observation. Nau, in 1836, spoke of a large tube which could be closed in a moment, for enclosing the objective designed uniquely for use at the Summer Solstice.

According to Lalande: As a matter of fact, he had used an objective of 82-3 feet for a gnomon of 75 feet in height. But it served its purpose excellently. [Actually for focussing the Summer Solstice sun correctly, the lens should have been of 114.3 feet focal length, 75 feet  $\div$  sin co-latitude of Paris, but the heat of the projected image would then have to be taken into account].

A marble tablet marks the Summer Solstice, Fig 9; it has the dimensions 0.898m by 0.896m [slightly under one yard square], and carries the inscription:

**SOLSTITIUM AESTIVIUM - ANNI MDCC XLV - ET PRO NUTATIONE - AXIOS TERREN - OBLIQUITATE ECLIPTICAE**

[Summer Solstice - Year 1745 - And Nutation of the Axis of the Earth, Oblivity of the Ecliptic].

The image of the Sun should be engraved there since Le Monnier wrote: *The terms of the major axis of the image of the Sun engraved in 1745 are marked in black to a depth sufficient to be seen without a glass; these terms have been engraved in the greatest elevation of the Sun*

and the axis of the elliptical image engraved in 1745 on the marble plaque is  $9\frac{1}{2}$  inches 2 lignes [0.26m]. [The image of the sun is elongated in the major axis because of the light striking the floor at an angle of  $49^\circ$ , if it struck at right angles it would be 0.1692m long (6.66 inches). A ligne is approximately  $\frac{1}{12}$  of an inch].

A metal plaque of the same dimensions protected the marble tablet, Fig 10. Le Monnier wrote: *And, because the marbles and above all the white marble became soiled by the feet of passers-by, the latter has been covered by a large copper plate which is not raised except at the time of observation [of the solstice].* It carries the inscription: OBLIQUITAS ECLIPTICAE MAXIMA  $23^\circ 28' 40''$ , 1744, made by Claude Langlois, Engineer to the Galleries du Louvre, MDCC XLIV (Maximum obliquity of the Ecliptic  $23^\circ 28' 40''$ , 1744).

Note that the marble tablet carries the date of 1745 whilst the copper plaque bears the date 1744. Le Monnier wrote: *It is not necessary to confuse this axis with that which Langlois engraved upon the upper plaque which covers the marble and which is of no importance to Astronomy nor in that which I wished to prove here. I have only furnished the following inscription: Obliquitas eclipticae maxima  $23^\circ 28' 40''$ , because I have discussed the famous question in our Memoires [of the Academy, 1745].*

The copper plate of the Equinoxes, of elliptical shape, behind the choir ballustrade swing door, indicates the position and form of the image of the Sun at the Equinoxes. It is 0.54m in length and 0.35m in width, see Fig 11.

The obelisk of the Winter Solstice was constructed by the Chevalier Servandoni. It serves to receive the image of the sun from the start of November to the end of

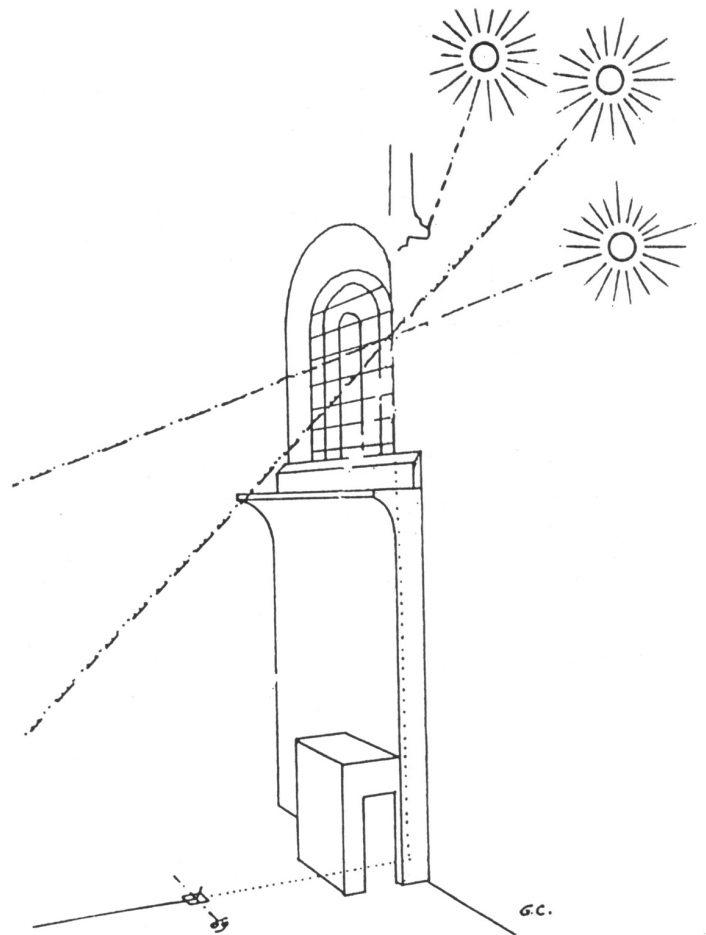

FIGURE 7: The sun's rays are blocked at the Summer Solstice by the exterior cornice

February. A pyramid, placed on a pedestal of 1.30m breadth, is surmounted by a gold ball and cross. The total height is 10.72m, Fig 12.

(To be continued)

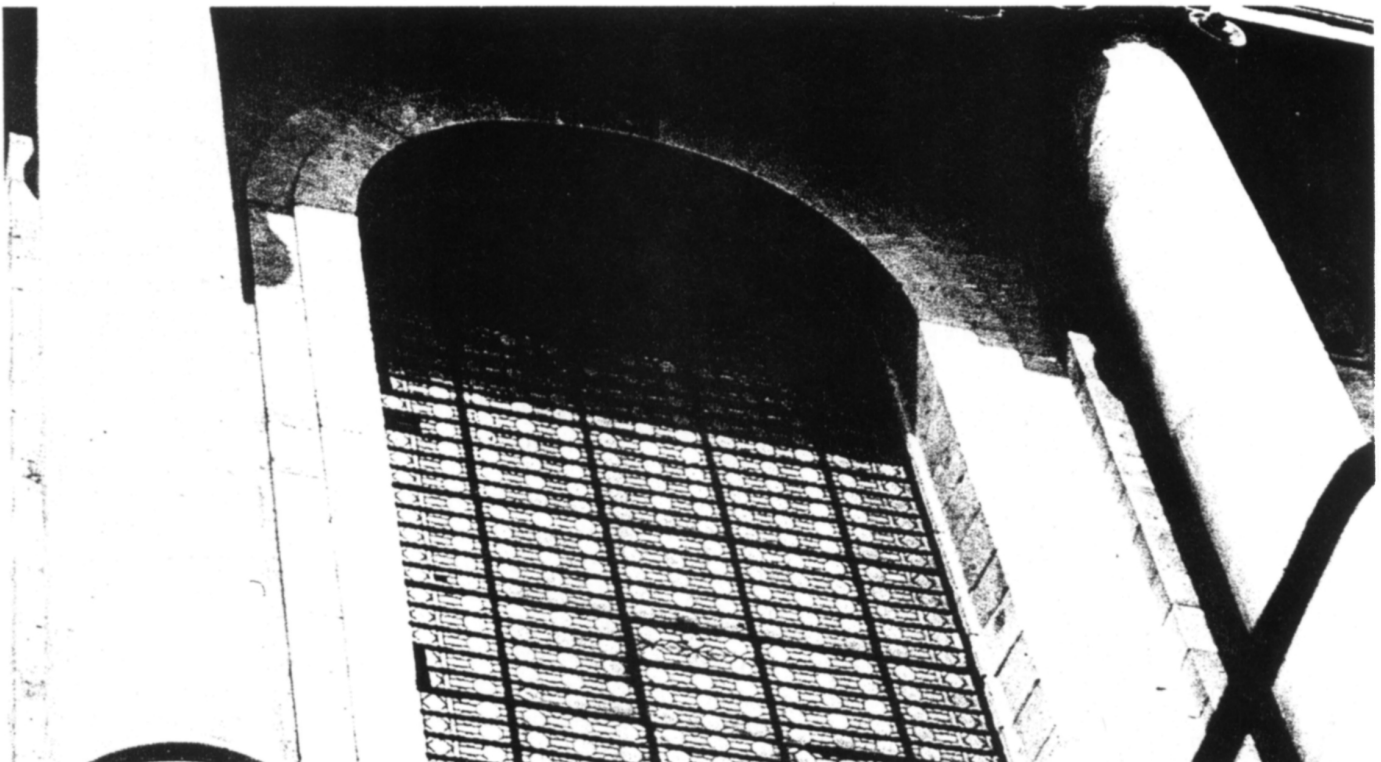

FIGURE 8: The stained glass window photographed from the street on 1 June, 1982

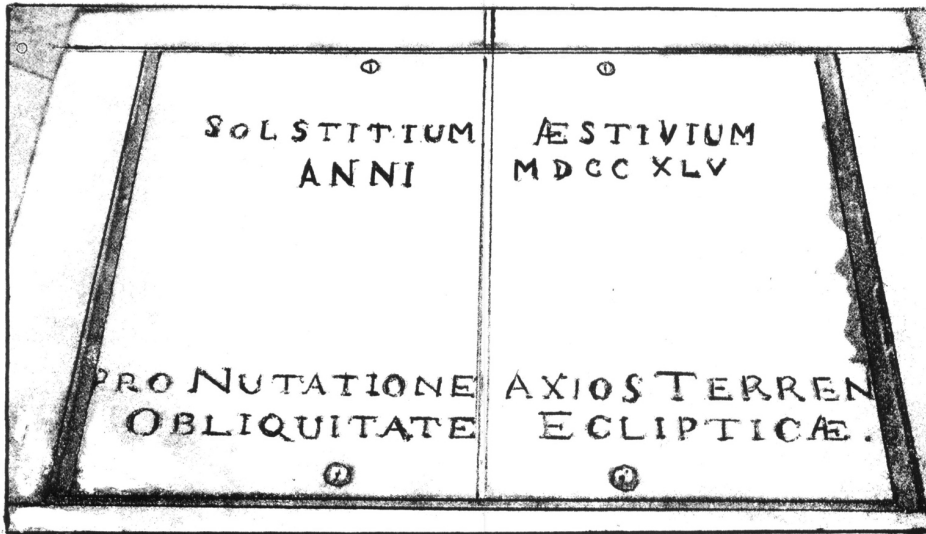

FIGURE 9: The marble tablet marking the Summer Solstice

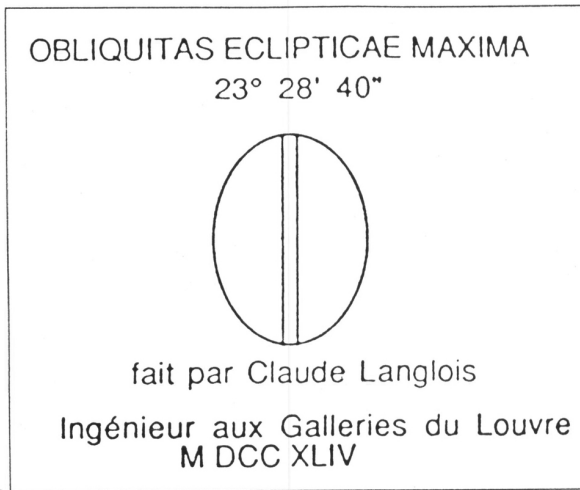

FIGURE 10: The lettering on the copper plaque which formerly covered the Summer Solstice marble tablet

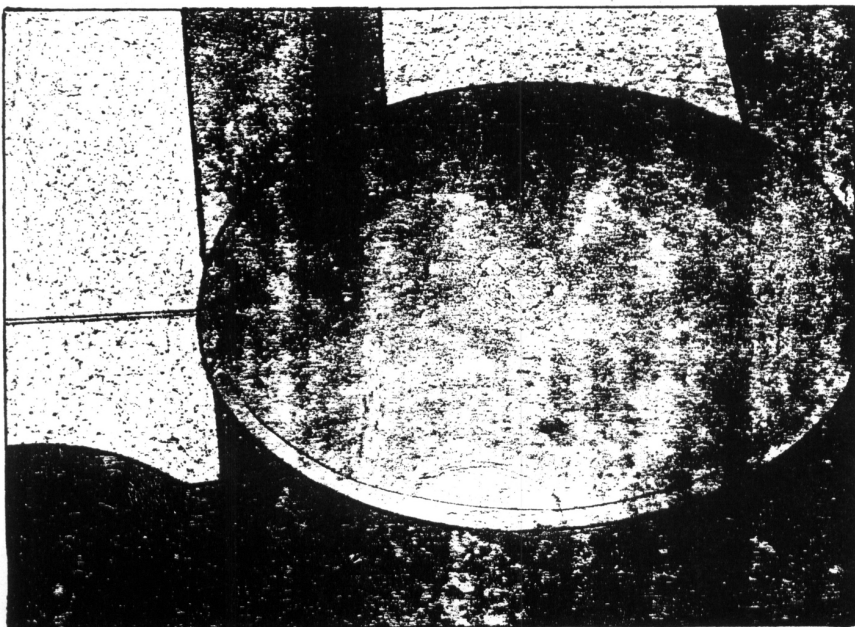

FIGURE 11: The oval copper plaque for the Equinoxes

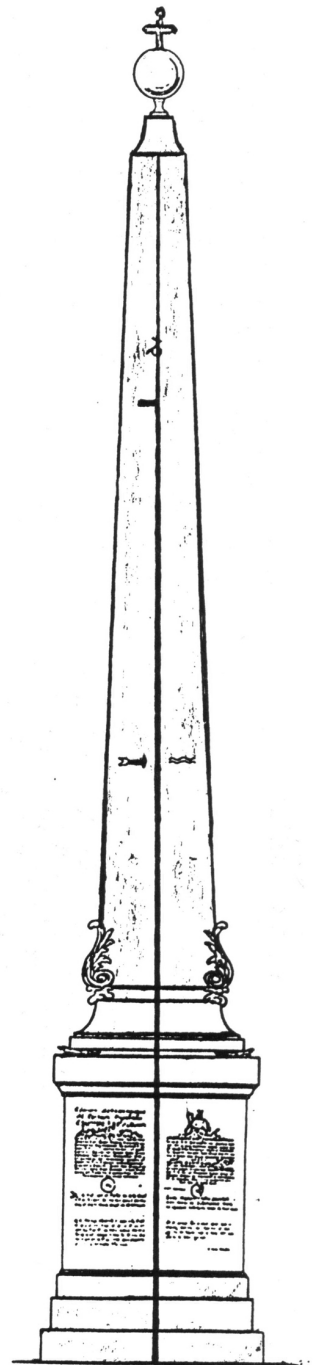

FIGURE 12: A reconstruction of the obelisk as it appeared before the Revolution

## BATH CONFERENCE 11th-13th SEPTEMBER, 1992

BY DAVID BROWN

There must be something about the Bath University campus which tends to create first confusion and then comfort followed closely by companionship. Fortunately the confusion part was quickly overcome by the 75 delegates who mysteriously and masterfully navigated their way to the remote common room which was to be the centre of their lives for almost two days. Old friendships were quickly re-established and new ones created around the magnificent collection of exhibits that mushroomed out of nowhere and gave plenty to occupy the all-too-few spare moments throughout the weekend. First attempts at sundials could be seen, as well as very elaborate craftsmen's pieces and connoisseurs', old and new. What always amazes me is the vast array of talents among the membership and several comments overheard indicated how much was the feeling of enthusiasm and inspiration which displays of this kind generate.

No sooner had we coped with the first of what was to be a succession of superb meals than we were into our first set of short talks. The lecture room was comfortably full to hear Colin McVean give an account of alternative ways to draw dials. I found this a little confusing and felt that a follow-up session would have been useful for those that wanted to clarify their understanding of Colin's approach. It will be good to see his work in print. Anne Somerville followed with a most attractive account of the human element in sundial safaris. There were many chords being struck here - we could relate our own experiences and rather meagre attempts at hunting for dials to those which Anne detailed and realise how far we fall short of the high standards set by our late founding Chairman Andrew Somerville. Thank you, Anne for a great Friday evening contribution. Finally, Michael Maltin flew a skilful course around the computer spreadsheet approach to sundial calculations. It would have been all too easy to turn off the audience at this stage, but in his elegant and humorous style he quickly dispelled any misgivings we may have had at the start, and showed us how powerful the computer technique can be in the right hands. A view was expressed afterwards that we should not let the computer take away from us the essential simplicity of simple dial construction (as extended by Colin) or the inherent beauty of the complex dial such as the Scottish polyhedrals illustrated by Anne. Nevertheless, there is more than one way to heaven!

Saturday dawned clear and bright with the promise of showers later. Would it stay fine for the open-topped bus tour later in the day? But after a good night's rest we were ready for more of the serious things of life! Philip Adams demonstrated a most beautifully-made model of the celestial sphere and his accompanying talk was the very model of a lucid lecture. Christopher Daniel followed with a learned and authoritative account of rare furniture - Domifying circles (reported elsewhere) and Laurence Price completed the session with a talk on his researches into Scratch Dials of Somerset. How nice to have something with a local flavour! The combination of these three talks seemed to turn out well, mixing basic ideas with the historical and the unusual.

Laurence was able to share his experiences with others after coffee in one of the workshop sessions, while Christopher Daniel shared his vast historical knowledge

about portable dials and the computer buffs got to grips with the recording formats under discussion. Yet again it was good to see that a small society such as this can reveal so many aspects of expertise amongst its members all with the central theme of the sundial.

But then it rained - so the open-top tour had to be switched into a closed-top tour. No problem! Badgerline had anticipated the weather and were happy to accommodate more than the expected number on a closed-top bus. So all was well. We soon discovered that not only did our guide know Bath thoroughly but that he had a certain music-hall style of presentation which kept us listening to all his wisecracks. All part of the service. Again, thanks to Badgerline we were able to go off the well-worn usual track of the City Tour and take in those sites which we were particularly interested in, where there were dials. In the space of the tour we were able to see an armillary sphere, a modern, rather plain and large dial on a new building put up for Bath CC (get working on your local councils!), a memorial cross dial, an analemmatic dial, a painted vertical declining dial, a heliochronometer and a new horizontal commemorative stone dial. The weather was uncertain, unfortunately, so the dials did not always tick for us, nor was there really enough time to browse around the dials and have our turn at getting close to them. Perhaps on your next, private, visit to Bath you will be able to go and view them again at your leisure. Who knows - there may even be a few more to see! The bus completed the tour by taking us back to the University and a chance for some to have a much-earned short afternoon siesta.

How good it was to have our president Sir Francis Graham-Smith as our guest for dinner! He was not expected to give a speech after such a hearty meal, but in a few short and apposite comments he conveyed to us that far from being an 'absent landlord' he is very much one of us. Moreover, not only is he promoting the creation of the sundial trail in the arboretum at Jodrell Bank, but he has taken the fateful step of making his own dial. If personal experiences are anything to go by, he is hooked! What a great idea to have an analemmatic dial arranged rather like a diving board over the garden pond in the only place in the garden where both pond and dial could go. One might say in such a context that this is a 'binary' dial to go with the stars of the same kind. Will it pulsate, I wonder?

The following morning - was it only just over a day since we assembled? - Sir Francis gave what can only be described as a superb lecture. How little did we suspect that we were in for such a treat as this. Did we organisers really think that the members could possibly cope with 'Pulsars as Clocks'? What in heaven is a pulsar anyway? We need not have worried. Here was the expert talking in laymen's terms about his own thing in such a way that the audience could absorb and appreciate what could so easily have been abstruse and unintelligible. An hour was all too short for this quality of speaker. The whole question of time that we in our own sweet way are dabbling with in our dials was thrown open to us to rediscover and wonder at. Is it really as ethereal and intangible when carved and painted and scribed and encompassed on our dial plates and circles? Yet how much more we can now feel that in some small way we are

perpetuating and getting engrossed in something that at the same time is being determined to miniscule proportions by the astronomer-horologists and by us - if we're lucky - to the nearest five minutes (whatever *they* are!). We look forward to more of these extending, enlightening, entertaining experiences.

The coffee break added to the inner glow and brought us down to earth ready for some quick reports on the workshop sessions and a fascinating account by Charles Aked of his visit to and researches on the Athens Tower of the Winds. This is reported in full detail elsewhere, but Charles gave us inspiration to be persistent in our own local hunts as we establish the true history of the dials we discover. Lunchtime had to be a farewell occasion for some of our members who had longer distances to travel, but the final session was devoted to an account by Piers Nicholson of the proposed Sundial Award Scheme. The details of this are noted elsewhere, but there was a useful and constructive discussion after his explanations, and many important points came to light.

So there we were. All over, bar the shouting. But not before thanks had been expressed to all concerned with the organisation of the conference - notable our tireless secretary David Young, to our Chairman Christopher Daniel who had steered us through most of the sessions with his own particular gentle firmness, to others who had chaired meetings, to the University for providing us with excellent accommodation, facilities and food, and not least to all those who attended for their promptness in communication with the organisers and in paying their monies and for their good humour and friendship. As one



Sir Francis Graham-Smith delivering his lecture "Pulsars as Clocks".

correspondent (who was not able to attend) stated - the Conference showed the Society to be in good shape.



One of the displays at the Bath Conference, Connoisseur Sundials

# AN UNUSUAL VARIETY OF AN EQUATORIAL SUNDIAL

BY ROBERT H MILLS

The photographs illustrate an equatorial sundial that may help beginners to understand how the Sun appears to progress across the visible celestial hemisphere at different times of the year, and how the path followed depends on the sun's declination and the date. This sundial is unusual in that it has no fixed gnomon. The model shown consists of a clear transparent plastic hemisphere, 45 cm in diameter, marked in degrees of azimuth from 0° to 360° round the periphery, which represents the horizon, with its centre at C. Z is the zenith of the hemisphere, and CP is a thin tapped metal rod which is inclined to the horizontal at an angle  $\phi$ , the latitude of the place. The celestial equator AB is marked in Hour Angles from 6<sup>h</sup> (due East, Azimuth 90°) to 12<sup>h</sup> (in the meridian plane, due South, Azimuth 270°). The equator thus marked represents the path of the Sun when its declination is 0°, at the time of the Equinox. When the model is set as shown, the Sun's path during the Summer Solstice (declination 23.4°) begins at sunrise at Azimuth 50° and ends with sunset at Azimuth 310°. The Sun on this path crosses the meridian at an angle of 62.° in altitude above the horizon. During the Winter Solstice (declination -23.4°), the path is from sunrise at Azimuth 129° to Azimuth at sunset 231°. It reaches its maximum altitude at noon transit, of 15.6° (39.0° - 23.4° = 15.6°). See Figures I and III.

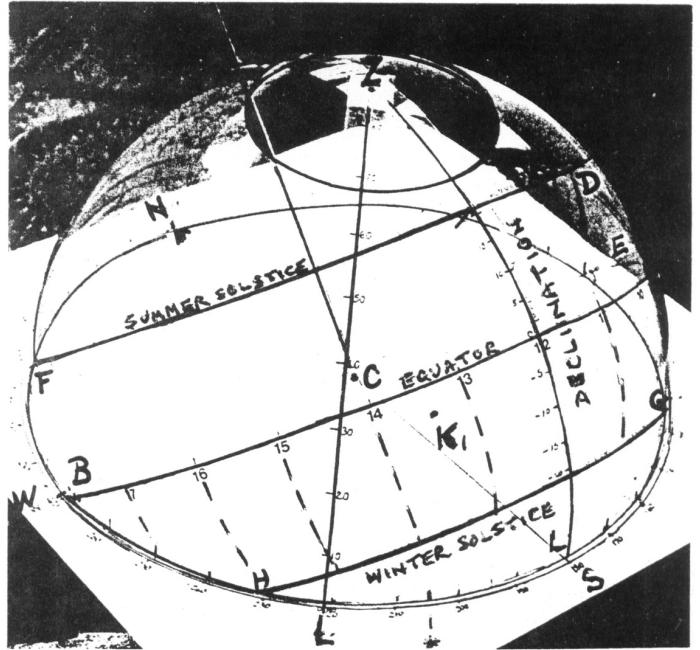

FIGURE I Position of the Sun on the hemisphere is at K when the shadow of the spot at K<sub>1</sub> falls on the centre C. The Sun time is 13h 25m. Alt. of the sun 26° Azimuth 205° Declination -5° and the approximate date is March 8th. These positions are shown by the cursor ZL when it is moved to cover K on the azimuth 205°.

FIGURE II A set of curves showing the Sun's position in altitude and azimuth on any date and at any time, using the Sun's declination. The dotted curve gives the Sun's declination on the dates shown on the top of the diagram. Along the bottom of the diagram

- A Shows the Sun's p.m. hour angles
- B Shows the Sun's a.m. hour angles
- C Shows the true Sun time p.m.
- D Shows the true Sun time a.m.

For the local mean time apply the equation of time.

*These provide a Sun compass and a Sun Clock.*

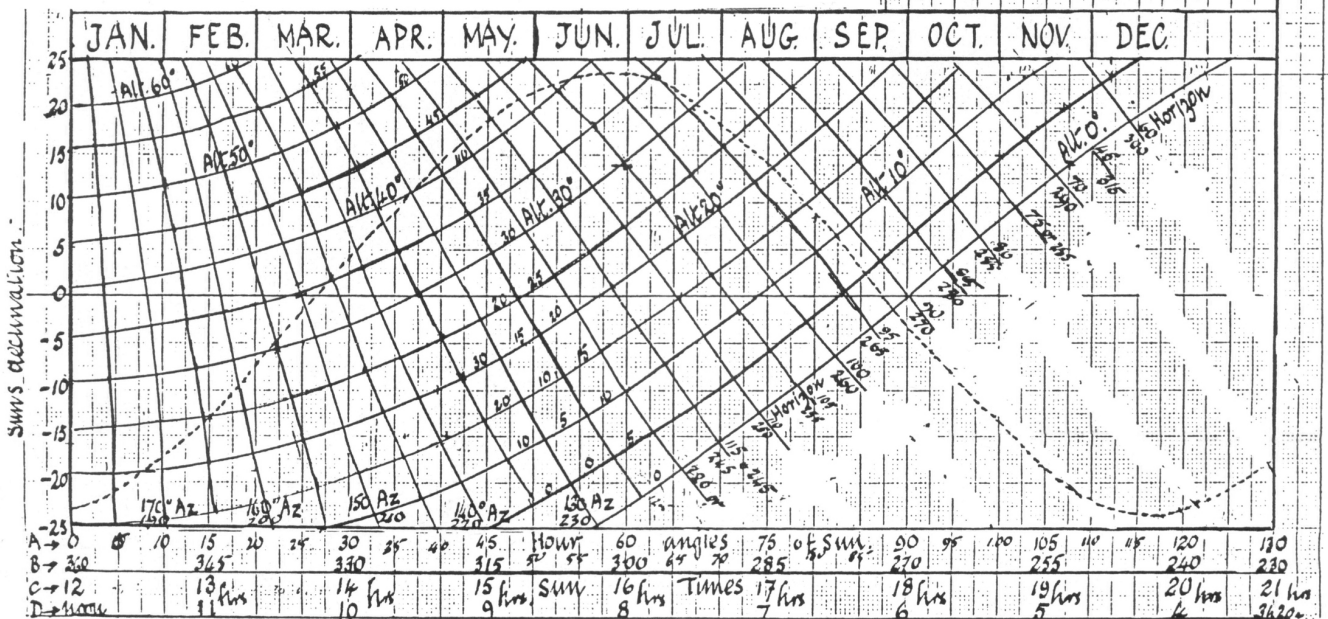

Example: On May 1st the sun is observed to have altitude 30°. From the dotted graph the sun's declination is 14°. The Azimuth of the sun is 106° (pm) or 254° (am) by interpolation between 100° and 110°. The sun time is seen to be 1555 (pm) or 0805 (am). This can be corrected for longitude and the equation of time. The times when the sun is on the horizon, sunrise and sunset, can be seen when the declination is known.

FIGURE III The figure shows on the circular disc, - reading from the periphery to the centre. 1 The Date, 2 The Azimuth of the rising or setting, 3 The angle at which the sun approaches or recedes from the horizon, 4 The Sun's declination, and 5 The approximate times of rising and setting, using Time of Rising = 12-LHA, and the time of setting = 12+ LHA.

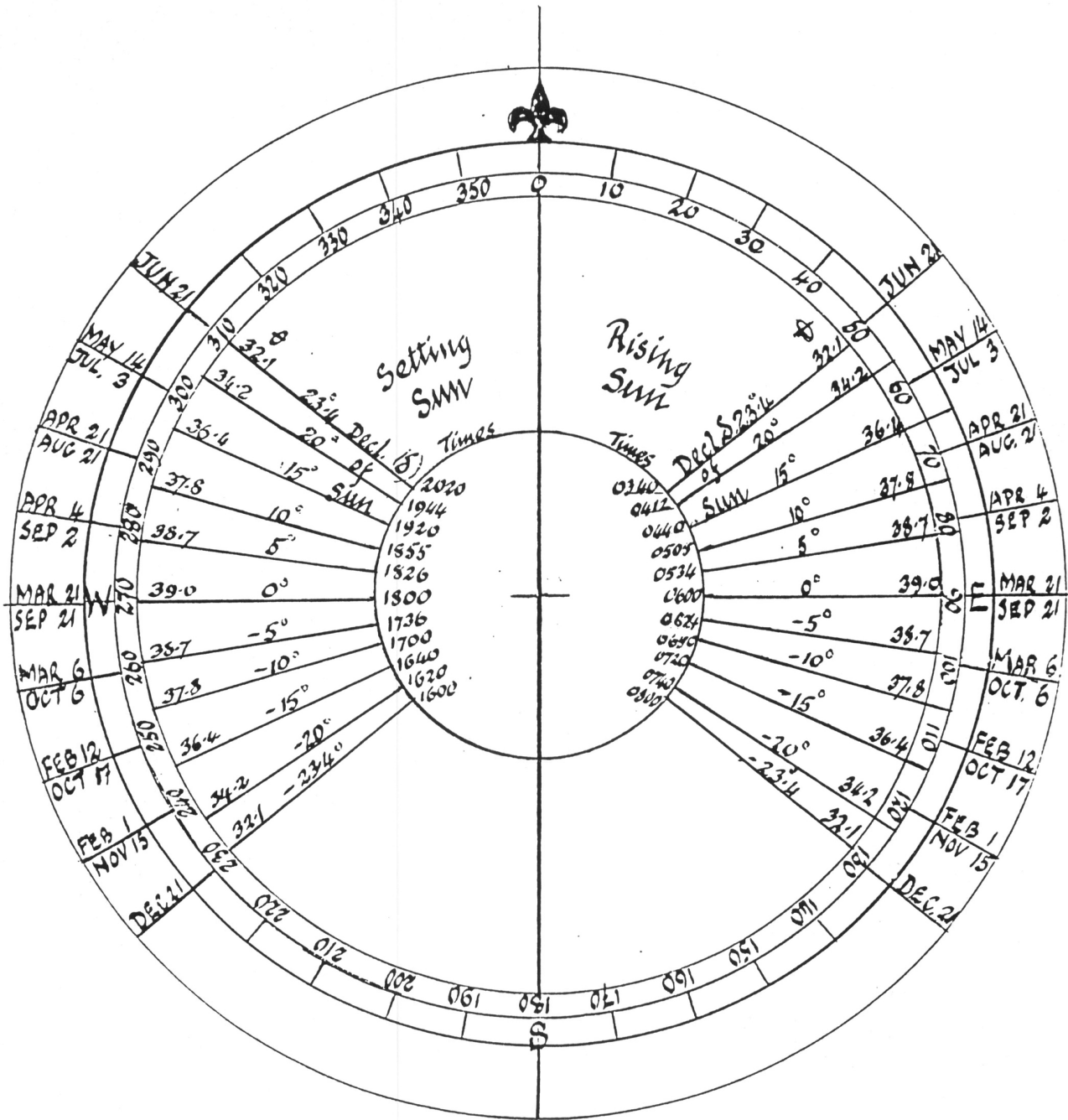

$\delta$  is the angle that the path of the Sun makes with the Horizon at the time of its rising or setting.

The Sun's position on the model can now readily be indicated by a knitting needle placed so that the shadow of the point falls on the centre C. The point on the model shows the Sun Time and the declination of the Sun. The needle point is also directly above the Sun's azimuth marked on the horizon circle.

All the essential parameters of the Sun's position at any instant can be observed with a little interpolation between the markings. It can be an interesting and rewarding exercise to check these observed results by using the "Sun" nomogram shown in Figure II, which

encapsulates the essential basic spherical trigonometrical formulae connecting the parameters. For those who are familiar with the use of the scientific calculator, it is satisfying to check the accuracy of the graphical results by using the two relations:

$$\sin a = \sin \delta \sin \theta + \cos \delta \cos \theta \cos HA$$

$$\text{and } \sin \delta = \sin \theta \sin a + \cos \theta \cos a \cos Az$$

Where a is the altitude, HA the hour angle, and  $\theta$  the latitude.

This nomogram demonstrates that it is possible to arrive at Sun time from the Sun's altitude alone providing

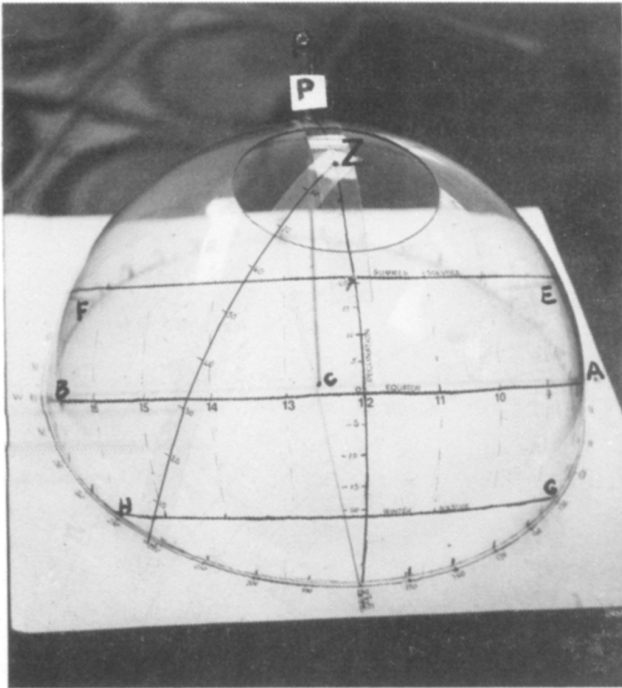

PHOTOGRAPH 1

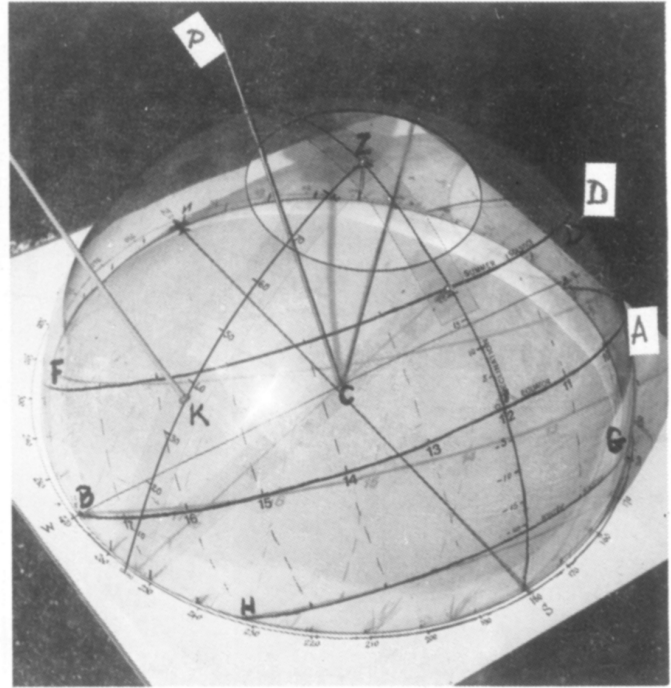

PHOTOGRAPH 2

the Sun's declination is known. Similarly, the Sun's azimuth with the declination can provide Sun Time. If however both the altitude and the azimuth are known, then the Sun's declination can be determined, which yields both the date (approximately) and the time. This note may give sundialists something to ponder over.

In order to facilitate the finding of the altitude and the azimuth of the Sun at any time, a narrow strip of flexible plastic can be used as cursor as indicated in the photograph. This cursor is marked in degrees from  $0^\circ$  to  $90^\circ$ , that is from the horizon to the Zenith. The  $90^\circ$  point is pivoted by a small bolt at the Zenith Z. To facilitate the

reading of the Sun's Hour Angle (the Sun Time), a length of thread can be used, passing from the Pole point on the hemisphere, and extending to the Sun's position on the hemisphere. A little interpolation may be necessary to obtain an accurate time.

The use of the altitude-azimuth cursor, together with the Hour Angle thread with convincingly demonstrate the danger that can befall beginners by confusing the Hour Angle of the Sun with its azimuth. This danger can lead to serious errors in direction finding by the Sun, using the so-called "Watch Rule", which is often erroneously advocated in books for adventure groups.

---

## SIR CHARLES WHEATSTONE'S SOLAR CHRONOMETER

This instrument consists of a tube, with a lens housed at its end, which is mounted on the polar axis, the tube being adjusted so that an image of the sun falls at the centre of a system of concentric rings which is housed in an aperture just above the watch dial. In doing this, gearing is employed to translate the angular movement of the tube into an indication of solar time on the watch type dial which is fixed on the polar axis.

The instrument is first placed on a firm horizontal surface, then levelled by means of the three levelling screws and the spirit level which can be rotated into any desired plane. A plumb bob might seem preferable since it can be used to correct all planes simultaneously, however this is impractical for outside use because of air currents. The two arced scales seen on the instrument are used to set the polar axis for the correct latitude (the lower scale), and the sun's declination (the upper scale). Both of these scales are fitted with vernier indications to allow accurate settings to be obtained.

In use, indications to about 10 seconds accuracy are obtainable by means of the graduations marked inside the minute indications, but accurate time indications are only possible by advancing the instrument slightly and noting when the image becomes centralised at the desired time. The delay in transferring the eye from the sun's image to the watch dial to read the time introduces a significant error, whereas if the time indication is set and the moment the image is correctly centred is noted, this delay is eliminated.

As the cost of producing such an instrument would exceed that of an accurate mechanical clock at the time, it is clear that the instrument was intended as a primary standard to set mechanical clocks by, at any time of the day when the sun was reasonably high in the sky.

Only one example of this device is known and it is exhibited at the Science Museum, South Kensington, London. If any member knows of other examples, please send details to the Editor.



# THE TOWER OF THE WINDS

BY CHARLES K. AKED

In response to several enquiries, some additional details are given here to supplement the previous article published in BSS Bulletin Issue No. 92.3, pages 9-16. It will be appreciated that the actual lecture was illustrated with many slides which could not be shown with the written version.

Figure 1 shows the Tower of the Winds as it was about sixty years ago and if it is compared with the views shown earlier, the details of the carvings are rather sharper; although the lines of the dials are very faint and cannot be reproduced here. The site shows the same kind of clutter then that still lies on the site. No doubt the sheer scale of the work required and the ultimate cost still deters those who wish to conserve these national treasures.

It may be of help in the understanding of the previous text if the dials shown in Figure 2 are examined. The view of the dials, is of course, that obtained if the viewer was facing these directly, they do not have the hour numerals on them as indicated here for convenience. Figure 2 is based upon that shown in *L'Ombra E Il Tempo* by Trincherio et al.

Figure 3 shows the model of the approximate faces of the Tower of the Winds made by Mr James Richard, who very kindly loaned it to the writer for the purpose of the lecture at the BSS Conference at Bath in September 1992, and its loan was much appreciated as the writer's diagrams of the dials have gone astray over the years. The model accurately indicates the time on the dials if tilted to the local latitude, for which purpose Mr Richard has fitted a support under the base. The dials show unequal hours, the ball tip of each gnomon serving as the shadow indicator.



FIGURE 1

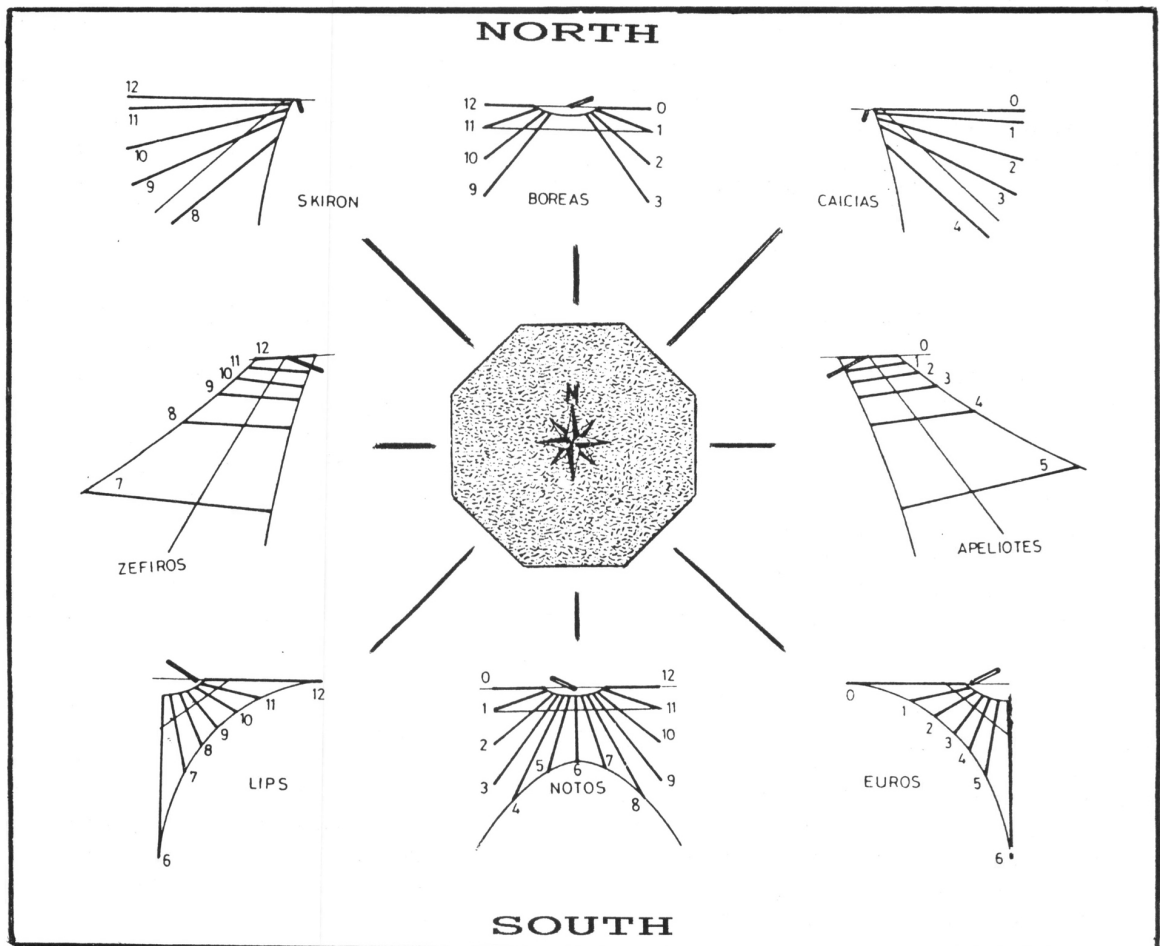

FIGURE 2:  
The sundials  
on the eight  
faces of the  
Tower of the  
Winds,  
Athens

Thanks to the kindness of Mr Ivor Slee, all the panels showing the allegorical representations of the eight winds are given in Figure 4. As with most carvings of great age, the figures appear rather better seen at a distance, on approach the mutilation and damage of the centuries became painfully obvious, in particular the engraved names of the winds are almost effaced. He also provided some photographs, including one of the plaque now placed near the Tower for the information of visitors, it also gives an illustration of the reconstruction of the Tower shown in the last figure of the previous article. These photographs were unfortunately not suitable for reproduction, it is not easy to find the correct conditions for good photography with a single visit to the Tower.

Through a slip of memory it was mentioned in the *previous article* that there was a replica Tower of the Winds at Alton Towers, this is incorrect, the reference should have been in respect of Shugborough, Staffordshire. The writer has not seen this example for himself up to the present. For the record, the model of the Tower mentioned previously was exhibited at "Ebel - The Architect of Time", 179 New Bond Street, London.

Details of the Tower of the Winds are given in *L'Ombre E Il Tempo* by Trincherio, Moglia and Pavanello, pages 94-95; a very fine book for those interested in dialling. Jean Baptiste Joseph Delambre also discusses the dials of the Tower of the Winds in his treatise *Histoire de l'astronomie ancienne ...*, Paris, 1817.

## THE EQUATION OF TIME - NOMONOIL

This time of the year is probably not the best to report a new scientific discovery as it might not be taken seriously. To allay the suspicions of readers and set their minds at rest, the heading has nothing to do with the lubrication of garden gnomes. It is meant for use by those with gardens, and especially those who have the classical feature of a sundial incorporated in its design.

Owners of sundials, especially the older types (of sundials), are only too well aware that when accompanying visitors around the hallowed plot, a first impulse of all visitors is to look at their quartz crystal watches, not to check them, but the indication on the sundial. This is obviously an inversion of true principles since the sun has long been recognised as the true timekeeper for mankind, and the unfortunate owner is forced to go into a long explanation of why there is a discrepancy between sundial time and Greenwich Mean Time because of the ellipticity of the earth's orbit and so on, and how it can be corrected by use of an Equation of Time Table. Unfortunately these tables engraved on metal or stone, often become illegible.

It has now been found possible to remove the difference in indications so that the sundial can read Greenwich Mean Time directly by a simple treatment applied annually, or perhaps twice in unusually severe weather conditions. This is done by the simple spraying of the indicating scale with Nomonoil. It does not leave any discernible residue, the initial darkening of the metal or stone quickly disappears, rather like the application of silicone waterproofing fluid to brickwork, which cannot be detected after drying out, but which effectively keeps out moisture. Similarly Nomonoil only demonstrates its presence during sunlight, when the invisible layer

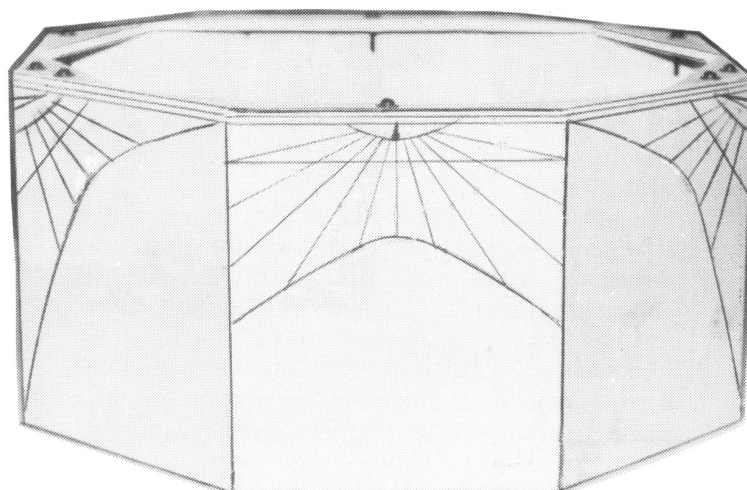

South Face

FIGURE 3

Nevertheless it would seem that much more research is necessary to discover how these dials were conceived and realized at such an early date. The designer must have been a mathematician of great skill with considerable knowledge of geometrical projection and understanding of the sun in its daily and yearly travels. The exact orientation of the Tower is evidence that the dials were intended to be incorporated from the beginning.

deposited reduces the friction of the indicating shadow.

It is this variable friction which is responsible for the variation of indication known as the Equation of Time, and although it cannot be eliminated entirely, its effect can be greatly reduced, to the extent that if the sundial is oriented correctly, the difference in time indication from Greenwich Mean Time will not exceed a few seconds at most, and this will be sufficiently accurate to obviate the sarcastic comments from those who know no better. The improvement thus obtained is greater with the very old sundials, and users may be assured that the formulation is guaranteed not to damage the surfaces in any way over decades of time, in fact it acts as a preservative, making time stand still as far as the surfaces are concerned since water and air are prevented from acting on the surface of the material; paradoxical as it may seem that one substance alone can correct the flow of time and also make it appear to halt it in other respects.

The sundial is one of Man's most ancient instruments and is still in use today, displaying an infinite variety of shape, sizes and concepts, of which only a few by special design were capable of the modern-day accuracy of modern clocks. Now this revolutionary treatment will make public clocks useful only on rainy days and avoid the situation such as in the middle of Bedford where St Paul's Church clock showed two different times, as did Bedford Market clock, in 1991.

The product, in liquid form, is not yet commercially available. The name Nomonoil is copyright and is derived from the shadow indicating component of every sundial - the gnomon. This term is of modern origin (C16) and is derived from the Greek word - *gignoskein* - to know - ie the Knowmon.

## THE TOWER OF THE WINDS, ATHENS



Boreas, the North wind



Skiron, the Northwest wind



Zephyros, the West wind



Lips, the Southwest wind



Notos, the South wind



Euros, the Southeast wind



Apeliotes, the East wind

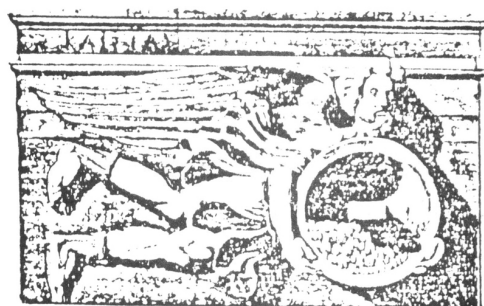

Kaikias, the Northeast wind

FIGURE 4: The Allegorical Figures representing the Eight Winds on the Tower of the Winds, Athens.

## LETTERS TO THE EDITOR

The Editor regrets that because of lack of space in previous issues, readers' letters have had to be held over until now.

### BULLETIN 92.1

I wonder how many members, including G.E. Taylor, have written to point out that the movable gnomon dial is equiangular. Its characteristic feature is that it can be drawn on any surface, horizontal, vertical, or inclined -which is normal to the meridian plane. The chosen inclination angle will determine the direction of the gnomon (rod), and its changing position in respect to the changing seasons.

It is not the dial pictured on page 15 a simple equatorial, I see no provision for moving the gnomon?

Can I be right in reading into the Moondial article (page 12) that the writer considers the spiral lines to be a new idea? The Drumlanrig Castle moon dial has a spiral pattern. Near to the Castle is the famous Oughtred double dial made by Henry Wynne (seventeenth century). It too has a moon dial with spiral lines. I think there is, or was, a similar dial at Windsor Castle.

I enclose photocopies of two ancient moon dials with spiral lines, Kircher's and a Lithuanian one (1781) from "Le Cadrans Lunaire" by L. Janin, sent to me by M. Denis Schneider, France.

Looking back to Bulletin 91.2, page 30, I think the writer was very unfair to Albert Waugh - many of his objections cannot be sustained.

I wonder if any BSS member can explain the "Psalm 91" dials, not that there is any connection between Psalms and dials.

GEORGE HIGGS

**Editor:** There was a slight mix-up with the illustrations and the wrong photograph was reproduced on page 15. The notes on Waugh were prepared by Noel Ta'Bois, alas he cannot reply to the criticism. Perhaps other readers might like to comment. The photocopies mentioned by Mr. Higgs are not reproduced here.

### MOONDIALS

The article in Bulletin No. 92.1 on Moondials by Rear Admiral Fantoni was fascinating. I would like to offer another variation on combining a moondial with a sundial.

I am making an equatorial sundial from an old cartwheel, the axle of which will be stuck into the lawn at the appropriate angle and which was going to be fixed in the rotational sense to indicate GMT (apart from the Equation of Time). Now, however, I am going to leave it so that it can be set at the time of the moon's transit, and having done this, the time can be read directly, providing the moon is shining.

The moon's transit time can be calculated by observation of the age of the moon as described by Rear Admiral Fantoni, or more easily obtained from any nautical almanac such as Reeds.

Is there any other correction to be made apart from the longitude difference from Greenwich? Has the Equation of Time to be applied to a moon-time reading?

ANDREW J. OGDEN



### SUN TIME FOUNDATION

BSS members may remember Mr. James Taylor who organized the Special Interest group for the BSS members interested in computers, he unfortunately died in 1991, the Editor was unable to publish an obituary as he was not able to secure the appropriate details. Mr. Taylor founded a small company called the Sun Time Foundation to manufacture small sundials intended as personal ornaments, a few of which are illustrated here. They range in price from £16 to £25 plus 70p postage. His wife has written to the Editor stating that she is continuing to run the business. Further details may be obtained direct from Sun Time Foundation, 95 Howards Lane, London SW15 6NZ, or telephone 081-788-5247.

### TOWER OF THE WINDS

In the course of your lecture on the Tower of the Winds you asked what the "aplustre" of a ship was and none of the members present could clarify this term.

"Aplustre" is a Latin noun (neuter) and, according to Lewis and Short's Dictionary, is "the curved stern of a ship, with its ornaments (ribbons, streamers, and little flags upon a pole)". The word occurs in Cicero, Caesar, and Lucretius, among others. The corresponding word in Greek is ἀπλαστου', which, according to Lidell and Scott's Lexicon, is "the curved stern of a ship, with its ornaments". The word occurs in the Iliad and (in the plural) in Herodotus, as well as elsewhere.

The Latin word is not an exact transliteration of the Greek. Strangely, there once occurs a Greek plural adjective ἀπλοῦστει , a comparative word meaning "less fit for sea", used for ships; but, although this would be transliterated into the Latin "aplustre", it really can't be relevant.

Describing the Tower of the Winds, the Blue Guide to Greece mentions Lips the South-West wind, which "driving before him the stern ornaments of a ship, promises a rapid voyage". Liddell and Scott say that the root of Λίψ is λείβω (the ultimate root of "libation") "because it brought wet". I don't know whether there is anything on the frieze to indicate that Lips brought rain.

JACK R BRADSHAW

**Editor:** There is only the single word Lips on the south-west frieze. Thanks Mr. Bradshaw for elucidating the term "aplustre".

#### THOMAS GRICE

During the summer whilst digging in the garden I had the luck to find a sundial. The sundial is 10 inches in diameter and the gnomon is present. The dial is engraved with a compass rose in the middle and around the periphery is the inscription:

"Seize the present moment the evening hour is nigh".

The dial is signed Thomas Grice 1705.

**Editor:** Two rather indistinct photographs were included with the letter (not from a member). A local antique dealer offered the enquirer £30 for the dial, declaring it to be a Victorian fake, but naturally the finder had set his sights on a rather larger amount. I had no hesitation in declaring it to be a modern replica because of the coarseness of the engraving of the motto, and such a motto was not used in 1705. I think there was a similar dial seen during the tour of the Edinburgh sundials, it was genuine at first sight until the engraving and the words used were considered. It may be one of the sundial range produced by the firm of Pearson, Page and Jewsbury, brass founders (now Peerage Brassware), at the beginning of the present century. The sundials which they produced were never intended to deceive but naturally being buried in soil for a long period adds a certain rustic finish which is a deceptive sign to untutored eyes hoping to have found a treasure. The enquirer did not reply to the letter setting out the reasons for declaring it to be a relatively modern creation.

#### SLATE LETTER-CUTTING

Mr Graham Stapleton has negotiated with the College at West Dean to arrange a course for those interested in cutting letters in slate in connection with dialling. The course will be held in October of 1993 - it is not possible to hold it earlier - providing at least six members wish to attend, the maximum in a group will be twelve. Places will be allocated on a first come, first served; if the demand justifies it, arrangements will be made for further courses. The course will take the form of a long weekend at the College - a very pleasant place to stay - it is a most pleasant situation not far from the beautiful city of Chichester where there are many attractions; the cost will be about £130.

It is understood from Ms Sally Hersh, the sculptor who will be the instructor, and who is a member of the British Sundial Society and has made her own sundials, that the course will cover both absolute beginners and those with some experience who wish to develop and practice their techniques.

Of course, as Ms Hersh points out, it is not possible to become a professional letter cutter in period of the course, but it will be a considerable help to those who have no knowledge of the subject, and often it is the first steps which are the most difficult ones to make.

All those who are interested are invited to write to Mr Stapleton at his home address:

50 Woodberry Avenue, North Harrow, Middlesex,  
HA2 6AX.

Please enclose a stamped addressed envelope for reply.

#### THE SCRATCH DIAL

In reference to these dials we are not dealing with ordinary people of the age, for time was the province of monks and learned men. The approximate indication of scratch dials was of no consequence in the absence of other horometers, Senéque stating that it was less difficult to get agreement between two philosophers than find the correct time in Rome, showing the problem arising when there are many time indicators of dubious accuracy. Since different types of horometers were in use (fire, water, candles, psalms . . .), there is a necessity to equate the use of all these time measurers.

In trying to resolve this question, from the Luxor or Vindonissia dials until the 14th century, duodecimal division was used, since AD 700 other modes of division appeared. What was the purpose of these alternative divisions? The immediate answer is indicating the time of the Great Mass, but since the 9th century private masses were celebrated, the times for these being struck in the town church, not by the monastic community. About the 13th C, to improve the division of days, modern time was born in the spirit of the times.

If duodecimal division was accepted as normal from Roman times, what could this division bring to those people devoted to monastic hours. It is a heritage of past customs, a copy of dials in former use? The choice between a 30° line and a 45° line does not provide a satisfactory answer. There was a greater choice offered by the duodecimal division to indicate the time for the striking of the bell for mass; partial or unequal divisions being a possible solution for each place where the Great Mass only was celebrated.

JEAN G. LAVIOLETTE  
(France)

#### THANKS

The Editor thanks the many members who have written to him expressing their appreciation of the various issues of the BSS journal, these are too many to publish here; members may rest assured that their comments are welcome after the considerable effort expended in knocking the contents into shape. Of course the contents are completely dependent upon the material sent in by those members who are willing to devote their time and effort into research, followed by writing it all up - no easy task. The editor would therefore like to express his grateful thanks to the many contributors who have made a quality publication possible over the last few years. As he has now succeeded in publishing most of the material sent to him, further contributions would be most welcome, see the notice on page 8.

In addition the Editor would like to express his thanks to all those who sent letters and cards during his recent spell in hospital, their kind thoughts were much appreciated. At present it seems that he will be able to continue in the post for the foreseeable future, but sooner or later, because of Anno Domini, someone will have to take over from him, so if there are any would-be editors in the membership, the BSS Council will be pleased to hear from you. The post requires a greater knowledge of publication skills than of dialling, although the latter is helpful.

---

## BIFILAR GNOMONICS

FREDERICK W. SAWYER, III

---

Bifilar gnomonics is the study of one of the few truly twentieth-century types of sundials. The bifilar sundial was invented in 1922 by Professor Hugo Michnik<sup>a\*</sup>, an Oberlehrer at the Kgl. Gymnasium in Beuthen, Upper Silesia, Germany (now Bytom, Poland). The dial has the advantage of having equiangular hour-lines: the lines all intersect in a single point and the angles between successive hour-lines are uniformly  $15^\circ$ . The usual sort of sundial, based on a gnomonic projection, does not display this uniformity in the placement of the hour-lines. Besides making the dial easier to construct, the equiangular feature permits a very easy daily adjustment of the dial face to give a direct reading of standard clock time rather than local apparent time: once the difference between the two times is determined for a given date and location, the required adjustment amounts to a simple rotation of the dial face through an angle whose size is proportional to that difference. Unlike other horizontal equiangular dials<sup>b</sup>, this one does not require an additional daily adjustment of the gnomon; indeed, in the case of the bifilar sundial, there is no gnomon to adjust. Instead of the usual shadow-casting device the dial uses two horizontal threads (hence the term 'bifilar') suspended at right angles to one another at appropriate heights above the dial face. Although the threads do not intersect, their shadows do; and it is their intersection which indicates the time.

The purpose of the present paper is to elaborate on Michnik's somewhat condensed treatment of the theory of the dial, thus making it more accessible to modern diallers. Besides reproducing Michnik's results and presenting a simplified justification of the construction, we will consider dials on arbitrary planes, a combination of dials which will indicate the time whenever the Sun is above the horizon, and general geometrical procedures for drawing Babylonian, Italian and sidereal hour-lines.

### Construction

In order to construct a bifilar sundial for a latitude north of the equator, begin with a circle of equiangular hour-lines: hours are marked clockwise around the circle at  $15^\circ$  intervals; each degree corresponds to 4 minutes of time. Suppose perpendicular lines NQS and EQW (figure 1) are drawn

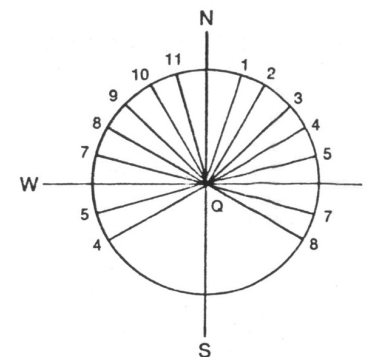

FIGURE 1.

on a horizontal base; the hour-circle should be attached to this base at its centre Q so that it can rotate freely. The line SN will represent the meridian; the direction from Q to N is north. Let O be a point on QN such that the segment QO has unit length. Suspend a thread horizontally above O in the east-west direction with height  $\tan \phi$ , where  $\phi$  is the geographical latitude at which the dial is to be used. Suspend a second thread horizontally above O in the north-south direction with height  $\sec \phi$ . To set the dial up, place it on a horizontal surface with the threads in the directions indicated, using true geographic north. Rotate the hour-circle so that the noon-line lies along the meridian QN. The intersection of the threads' shadows on the dial face will register local apparent time. Alternatively, if the hour-line corresponding to the (clock) time at which the Sun crosses the meridian on any given day is made to lie along QN, then the dial will agree with the clock throughout the day.

There are a number of ways to determine the direction of true north, the easiest of which uses the dial itself with an accurate clock. After rotating the dial face to indicate Standard (or Summer) Time, rotate the entire dial base until the correct time is read; the dial will then be correctly oriented and will continue to give correct readings throughout the year with only the minor modifications already noted.

Local noon, the time of the Sun's crossing the meridian for any given day and location, may be determined by reference to the Equation of Time (a table which is available in most almanacs). To determine the Standard Time of local noon, the appropriate entry in the table is to be added algebraically to the base time which is noon plus  $4(\lambda - \lambda')$  minutes, where  $\lambda$  is the longitude, expressed in degrees, of the dial's location and  $\lambda'$  is the standard meridian of the dial's time zone. During Summer Time, of course, an additional hour must be added. Alternatively, local noon may be determined simply as the time midway between local sunrise and sunset.

---

\*The letters refer to notes at the end of this paper.

For a dial south of the equator the hours are marked counterclockwise around the circle. The point O should be selected on the southern line segment QS which now corresponds to the noon-line. The heights of the threads above O are the same as they would be for a dial at the corresponding latitude above the equator<sup>c</sup>.

### Justification

Suppose that the threads on the dial are attached to a vertical rod with base at point O. In figure 2, the shadow of this rod is OR; lines UP (parallel to QE) and RP (parallel to QN) are the shadows of the threads, and P is therefore the intersection of the shadows. We will need the following identities:

$$\cos h \cos A = \sin \phi \cos \delta \cos t - \cos \phi \sin \delta \quad (1)$$

$$\cos h \sin A = \cos \delta \sin t \quad (2)$$

$$\sin h = \sin \phi \sin \delta + \cos \phi \cos \delta \cos t \quad (3)$$

where  $t$  = solar hour-angle;  $A$  = solar azimuth;  $h$  = solar altitude;  $\delta$  = solar declination.

In order to justify the equiangular construction of the dial described above, we need to establish that the angle  $w$  between the meridian line QN and the hour-line QP is equal to the Sun's hour-angle  $t$ .

$$\overline{OU} = \tan \phi \cot h \quad \overline{OR} = \sec \phi \cot h$$

$$\begin{aligned} \tan w &= \overline{PV}/\overline{QV} = \overline{RT}/(1 + \overline{OV}) \\ &= \sec \phi \cot h \sin A / (1 + \tan \phi \cot h \cos A) \\ &= \cos h \sin A / (\cos \phi \sin h + \sin \phi \cos h \cos A) \\ &= \cos \delta \sin t / (\cos^2 \phi \cos \delta \cos t + \sin^2 \phi \cos \delta \cos t) \\ &= \tan t \end{aligned}$$

Thus,  $w = t$  and the equiangular bifilar sundial is justified. The case for a southern dial is similar.

### Optimum radius

One drawback of the bifilar sundial is that it does not indicate the hour for the entire time that the Sun is above the horizon; as the Sun rises or sets, the distance QP from the centre to the point of intersection of the shadows becomes larger than the radius of the dial. Referring to figure 2, the distance QP is determined as follows:

$$\begin{aligned} \overline{QP} &= \overline{PV}/\sin w = \sec \phi \cot h \sin A \operatorname{cosec} t \\ &= \sec \phi \operatorname{cosec} h \cos \delta \quad \text{by (2)} \end{aligned}$$

$$= \sec \phi / (\sin \phi \tan \delta + \cos \phi \cos t) \quad \text{by (3)}$$

Thus the latest hour-angle  $t_f$  which can be read on a dial of radius  $\rho$  (in units equal to the distance QO) for a given declination  $\delta$  is determined by setting  $\overline{QP} = \rho$  and solving for  $t$ :

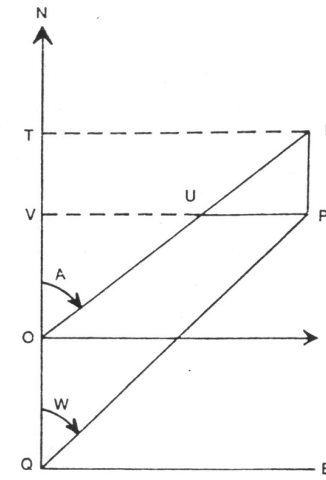

FIGURE 2.

$$t_f = \cos^{-1}[(1 - \rho \cos \phi \sin \phi \tan \delta) / (\rho \cos^2 \phi)] .$$

The hour-angle  $t_s$  of sunset for a given day and latitude is

$$t_s = \cos^{-1}[-\tan \phi \tan \delta] .$$

As a guide for the selection of a convenient radius, values for the ratio  $t_f/t_s$  of these hour-angles appear in Tables I and II for latitudes  $40^\circ\text{N}$  and  $51^\circ 30'\text{N}$ , respectively. A procedure for constructing a combination of dials which indicates the time whenever the Sun is above the horizon will be discussed below.

TABLE I

VALUES OF THE RATIO  $t_f/t_s$  FOR LATITUDE  $40^\circ\text{N}$

Radius	Summer Solstice	Equinox	Winter Solstice
3	0.703	0.615	0.310
4	0.776	0.720	0.551
5	0.820	0.779	0.658
6	0.849	0.817	0.723
7	0.870	0.843	0.766
8	0.886	0.863	0.798
9	0.899	0.879	0.822
10	0.909	0.891	0.840

### Dials for arbitrary Planes

Although we have been considering dials which lie on a horizontal plane, it is possible to construct a bifilar dial for any given plane. Suppose

we draw a north-south line  $N_1QS_1$  and an east-west line  $E_1QW_1$  on a horizontal plane and then rotate the plane through an angle  $i$  about  $E_1W_1$  so that the line segment  $QN_1$  is above the horizon. Suppose further that the plane is then rotated clockwise about the vertical line  $QZ$  (where  $Z$  is the zenith point directly overhead) through an angle  $d$ . As a result of these rotations the plane is said to have inclination  $i$  and declination  $d$ . In order to construct a dial on an arbitrary plane the only information needed in addition to the dial's latitude is the inclination and declination of the plane on which it is to rest. Throughout the following, the line  $QN_1$  (figure 3) on a given plane will be understood to be the north ray of the line  $N_1QS_1$  which is obtained in the manner just described: beginning as a horizontal meridian line and then being rotated so that it lies on the given plane.

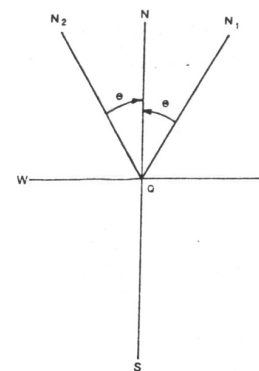

FIGURE 3. (The angle  $N_2QN$  should be  $\theta'$ .)

TABLE II

VALUES OF THE RATIO  $t_f/t_s$  FOR LATITUDE  $51^\circ 30'N$

Radius	Summer Solstice	Equinox	Winter Solstice
3	0.582	0.341	—
4	0.685	0.554	—
5	0.745	0.655	—
6	0.785	0.717	0.225
7	0.814	0.760	0.421
8	0.836	0.791	0.523
9	0.853	0.815	0.592
10	0.867	0.834	0.642

Now to construct an equiangular bifilar sundial for latitude  $\phi$  on a plane with inclination  $i$  and declination  $d$ , begin by selecting a point  $Q$  on the plane and draw the line segment  $QN_1$ . Draw the perpendicular lines  $NQS$  and  $EQW$  (figure 3) with the angle  $\theta$  from  $QN_1$  to  $QN$  determined as follows:

$$\cos \theta = \frac{\tan \phi \sin i + \cos d \cos i}{((\tan \phi \sin i + \cos d \cos i)^2 + \sin^2 d)^{1/2}}$$

where the direction from  $QN_1$  to  $QN$  is counterclockwise if  $d$  is positive and clockwise if  $d$  is negative.  $QN$  is the intersection of the given plane with the plane determined by its pole and the celestial axis.

Alternatively, the lines  $NQS$  and  $EQW$  may be determined by first drawing the north-south line  $QN_2$  (figure 3); *i.e.* the line which is the intersection of the given plane and the meridian plane. The angle  $\theta'$  from  $QN_2$  to  $QN$  is determined as follows:

$$\tan \theta' = \frac{\sin \phi \cos i - \cos \phi \sin i \cos d}{\sin \phi \cot d + \cos \phi \cot i \operatorname{cosec} d}$$

Now at latitude  $\phi$  and longitude  $\lambda$  a plane with inclination  $i$  and declination  $d$  is parallel to a horizontal plane at latitude  $\alpha$  and longitude  $(\lambda + t')$ , where longitude is understood to increase to the west, and

$$\sin \alpha = \sin \phi \cos i - \cos \phi \sin i \cos d \quad (4)$$

$$\sin t' = \sin i \sin d \sec \alpha$$

$$\cot t' = \sin \phi \cot d + \cos \phi \cot i \operatorname{cosec} d \quad (5)$$

Moreover, if north-south and east-west lines were drawn on that horizontal plane, they would be parallel respectively to the lines  $NS$  and  $EW$  which have already been drawn on the given plane. We can therefore simply construct the dial over these lines as before, but in doing so we must use  $\alpha$  as our latitude as though the plane were displaced to the location in which it would be horizontal.

The dial is now complete, but it is important to note that the point  $N$  (or, if  $\alpha < 0^\circ$ , the point  $S$ ) no longer corresponds to local noon but rather to the hour-angle  $t'$  (*i.e.* the time past noon expressed in degrees, where  $1^\circ$  equals 4 minutes of time).

As examples, suppose first that we wish to construct at latitude  $40^\circ N$  a vertical sundial which faces directly south. For such a dial we have  $i = 90^\circ$  and  $d = \theta = \theta' = 0^\circ$ ; the line  $NS$  is vertical. Further calculation yields  $\alpha = -50^\circ$  and  $t' = 0^\circ$ . The dial to be constructed may thus be treated as though it were a horizontal dial at latitude  $50^\circ S$ .

Since the distance from the shadows' intersection to the centre of the horizontal dial is generally greater when the Sun is low above the horizon, a vertical dial used at a northern latitude will be easier to read during the spring and summer than will a horizontal one: during these seasons the Sun is low in the sky at the southern latitude whose horizontal plane is parallel to the vertical dial. However, although such a dial would be



TABLE III

USABLE PERIOD OF DIALS WITH RADIUS 2.95 AT LATITUDE 40°N

	<i>East</i>	<i>Horizontal</i>	<i>West</i>
Summer Solstice	4:35–10:41	6:49–5:11	1:19–7:25
Equinoxes	6:00–10:41	8:21–3:39	1:19–6:00
Winter Solstice	7:25–10:41	10:41–1:19	1:19–4:35

easier to read, it would indicate time during a smaller portion of the daylight.

Now suppose that at latitude 40°N we want a vertical dial facing directly east, so that  $i = 90^\circ$ ,  $d = -90^\circ$  and  $\theta = +50^\circ$ , where the positive value for  $\theta$  indicates a clockwise measurement from  $QN_1$  to  $QN$ . The line  $QN_1$  is again vertical, so  $QN$  is parallel to the celestial axis. Since  $\alpha = 0^\circ$ , the dial may be constructed as though it were in either hemisphere, the different choices determining the placement of the point  $O$  and whether the hours are marked in a clockwise or counterclockwise sense. Because  $t' = -90^\circ$ , the line  $QN$  (or  $QS$ , depending on the placement of  $O$ ) is now the hour-line for 6 am local apparent time. The resulting dial is equivalent to the classical vertical direct east dial.

Direct east and west dials may obviously be used to read early morning and late afternoon hours, respectively. A combination of these dials with a horizontal one, all of them being displayed, for example, on the faces of a cube, will indicate the time whenever the Sun is above the horizon, provided their radii are chosen appropriately. Thus, if all three dials have the radius 2.95 (where the line  $QO$  has unit length) at latitude 40°N, the time during which each dial is usable is given in Table III for selected dates.

The equations for determining appropriate values for the radius  $\rho$  are complex. On the simplifying assumption that the dials share a common radius and are either horizontal or vertical, the value chosen for  $\rho$  must be such that conditions (6) and (7) hold, where  $\epsilon = 23;26^\circ$ .

$$\cos^{-1} [(1 + |\rho \cos \phi \sin \phi \tan \epsilon|) / (\rho \cos^2 \phi)] + \cos^{-1} [1/\rho] \geq 90^\circ \quad (6)$$

$$\cos^{-1} [-|\tan \phi| \tan \delta] - \cos^{-1} [1/\rho] \leq 90^\circ \quad (7)$$

The first condition guarantees that the dial combination records the time whenever the Sun is above the horizon between 6 am and 6 pm; the second imposes a similar guarantee for earlier risings and later settings of the Sun. It can be shown that whenever condition (6) is satisfied, so is condition (7). Thus the minimum—and, from the point of view of readability, the best—value for  $\rho$  at latitude  $\phi$  is obtained by considering the case of equality in (6) and solving for  $\rho$ . This yields the following equation:

$$\rho = K + \sqrt{K^2 + (\sec^2 \phi + \cos^2 \phi) / (1 - \sin^2 \phi \sec^2 \epsilon)}$$

where  $K = |\tan \phi \tan \epsilon| / (1 - \sin^2 \phi \sec^2 \epsilon)$ .

At latitude 40°N, this equation gives the value  $\rho = 2.95$ ; at latitude 51° 30' N we have  $\rho = 5.86$ . Additional values for various latitudes are given in Table IV.

Throughout the following, the equations to be given apply to horizontal dials; however, appropriate adjustments may be made to adapt them to dials on arbitrary planes.

TABLE IV

OPTIMUM RADII FOR BIFILAR CUBE DIALS

$\phi$	$\rho$	$\phi$	$\rho$	$\phi$	$\rho$
30°	2.11	40°	2.95	50°	5.21
31°	2.17	41°	3.08	51°	5.63
32°	2.23	42°	3.23	52°	6.11
33°	2.30	43°	3.39	53°	6.68
34°	2.37	44°	3.57	54°	7.35
35°	2.45	45°	3.77	55°	8.14
36°	2.53	46°	3.99	56°	9.11
37°	2.62	47°	4.24	57°	10.29
38°	2.72	48°	4.52	58°	11.77
39°	2.83	49°	4.84	59°	13.67

### General theory

The justification given earlier for equiangular bifilar sundials presupposed that the heights of the two threads were known. The general development to be given here makes no such supposition and, as a result, it will demonstrate not only that the values already given are the only ones which produce an equiangular dial, but also that a variety of different (non-equangular) dials may be obtained by appropriate changes in the heights.

Consider a rectangular co-ordinate system with origin at point  $O$  and such that the  $x$  and  $y$ -axes are directed east and north, respectively (see figure 2). Suppose that horizontal threads are suspended above  $O$ , one along the  $y$ -axis at height  $g_1$  and the other along the  $x$ -axis at height  $g_2$ . As before, suppose that a solid vertical rod has its base at  $O$ ; then  $P$  is the intersection of the shadows of the threads, and

$$\overline{OU} = g_2 \cot h$$

$$\overline{OR} = g_1 \cot h$$

The co-ordinates of  $P$  are

$$x = g_1 \cot h \sin A \quad (8)$$

$$y = g_2 \cot h \cos A \quad (9)$$

Using the identities (1)–(3) above, these equations may be transformed into the following:

$$x = g_1 \sin t / (\sin \phi \tan \delta + \cos \phi \cos t) \quad (10)$$

$$y = g_2 (\sin \phi \cos t - \cos \phi \tan \delta) / (\sin \phi \tan \delta + \cos \phi \cos t) \quad (11)$$

Solving these equations for  $\tan \delta$  and then eliminating this parameter yields an equation for the hour-lines<sup>d</sup>, dependent only on  $\phi$  and  $t$ :

$$g_2 x \cot t - g_1 y \sin \phi = g_1 g_2 \cos \phi$$

Since this equation is linear in  $x$  and  $y$ , the sundial has straight hour-lines. All of these lines intersect in one point  $Q$ , the  $y$ -intercept (obtained by setting  $x = 0$ ).

$$x = 0 \rightarrow y = -g_2 \cot \phi \quad \overline{QO} = g_2 \cot \phi$$

$$y = 0 \rightarrow x = g_1 \cos \phi \tan t \quad \overline{OV} = g_1 \cos \phi \tan t$$

Suppose we choose our unit length so that  $\overline{QO} = 1$ ; then  $g_2 = \tan \phi$ .

We also have  $\tan w = \overline{OV} / \overline{QO} = k \tan t$ , where  $k = g_1 \cos \phi$ . In order to obtain an equiangular dial ( $w = t$ ) we must set  $k = 1$ ; we then have  $g_1 = \sec \phi$ .

However, suppose now that we relinquish the equiangular requirement. Then a variety of dials may be constructed corresponding to different values for  $k$ . As an example, suppose we have a usual sort of horizontal (hour-arc) dial constructed for latitude  $\phi'$ . If we identify the meridian line of this dial with  $QON$  and the centre of its hour-lines with the point  $Q$ , then any text on gnomonics will tell us that

$$\tan w' = \sin \phi' \tan t$$

We can therefore adapt the dial for latitude  $\phi$  and still keep it horizontal by removing the gnomon and erecting a horizontal east-west thread above point  $O$  at height  $\tan \phi$  and a similar north-south thread at height  $\sin \phi' / \cos \phi$ ; that is, simply set  $k = \sin \phi$ . If  $\phi = \phi'$ , then  $g_1 = g_2$  and we have an ordinary horizontal dial.

### Day curves

On many sundials there are curves drawn to trace the path of the shadow of a particular point on the gnomon for selected dates. While this practice would serve no purpose in an equiangular bifilar sundial with a rotating dial face (unless of course the face were transparent and the curves were drawn on the non-rotating base), nevertheless one may determine exactly what these curves will be in general. The curve we will consider is traced by the intersection of the threads' shadows.

From equation (11) we have

$$\cos t = \tan \delta (g_2 \cos \phi + y \sin \phi) / (g_2 \sin \phi - y \cos \phi)$$

Using this result in equation (10) yields

$$\sin t = g_2 x \tan \delta / (g_1 g_2 \sin \phi - g_1 y \cos \phi)$$

Since  $\sin^2 t + \cos^2 t = 1$ , we have

$$\tan^2 \delta (g_2^2 x^2 + g_1^2 (g_2 \cos \phi + y \sin \phi)^2) = g_1^2 (g_2 \sin \phi - y \cos \phi)^2$$

Finally, by means of the identity  $\cos^2 \phi = 1 - \sin^2 \phi$ , we have the following equation of the day curve<sup>e</sup>, dependent only on  $\phi$  and  $\delta$ ,

$$\sin^2 \delta (g_2^2 x^2 + g_1^2 y^2 + g_1^2 g_2^2) = g_1^2 (g_2 \sin \phi - y \cos \phi)^2$$

Note, however, that this equation is based on considering  $O$  as the origin. If  $Q$ , the centre of the equiangular dial, were used as the origin, the variable  $y$  would have to be replaced by  $(y - g_2 \cot \phi)$ .

On the equinoxes, when  $\delta = 0^\circ$ , the day curve becomes a straight line from west to east. More generally, the form of the curve on any given day may be determined from Table V.

For a horizontal equiangular dial (constructed say for a northern latitude), it is probably easier to trace the day curves by using polar co-ordinates with  $Q$  as origin, since at any time  $t$  the point  $P$  has the polar co-ordinates  $(t, \overline{QP})$ .

TABLE V

THE FORM OF THE DAY CURVE ON SELECTED DATES

Solar Declination	Day Curve
$\delta > 90 - \phi$	ellipse
$\delta = 90 - \phi$	parabola
$\delta < 90 - \phi$	hyperbola

### Altitude and azimuth curves

In addition to day curves, a dial may be furnished with curves of equal solar altitude or azimuth. Thus, for example, on a bifilar sundial with curves for altitude  $h = 30^\circ$  or azimuth  $A = 40^\circ$ , the intersection of the shadows will lie on one of these curves exactly when the Sun has altitude  $30^\circ$  or azimuth  $40^\circ$ , respectively.

The equation for altitude curves is obtained by eliminating the parameter  $A$  from equations (8) and (9) to obtain

$$(x \tan h / g_1)^2 + (y \tan h / g_2)^2 = 1$$

The resulting curve is an ellipse.

Using equations (8) and (9) again, but this time eliminating the parameter  $h$ , we have

$$y = (g_2 / g_1) x \cot A$$

The azimuth curve is thus a straight line through the origin  $O$ . The line corresponding to solar azimuth  $A$  itself has an azimuth  $A'$ , where  $\cot A'$  is the slope  $(y/x)$  of the line. For an equiangular dial the two angles are therefore related to each other as follows:

$$\cot A' = \sin \phi \cot A$$

### Babylonian and Italian hour-lines

As a general rule in gnomonics, the zero-point for determining the hour-angle of the Sun for any particular location is local noon, when the Sun is on the meridian. However, this need not be the case; we will consider here two other well-known systems: the Babylonian, which reckons time from the preceding sunrise, and the Italian, which reckons time from the preceding sunset. Consider a sundial which has both Babylonian and Italian hour-lines but on which the Italian lines are numbered in reverse, so that sunset is 0 hours, while one hour before sunset is 1 hour. Such a dial may be used to determine at any given time how many hours have elapsed since sunrise (the Babylonian hour  $b$ ), how many hours remain until sunset (the reversed Italian hour  $i$ ), how many hours of daylight there are on the given day ( $b+i$ ), and the local apparent time  $\frac{1}{2}(b-i)$ , where a zero value for  $t$  denotes local noon.

If we let  $T$  be the time from sunrise to noon on any given day and let  $b$  be the Babylonian hour, then

$$t = b - T \quad \text{and} \quad \cos T = -\tan \phi \tan \delta.$$

Substituting these equations into the equations (10) and (11) for the co-ordinates of the point P yields:

$$x = \frac{g_1 (\sin b - \cos b \tan T)}{(\cos \phi \cos b + \cos \phi \sin b \tan T - \cos \phi)}$$

$$y = \frac{g_2 (\sin \phi \cos b + \sin \phi \sin b \tan T + \cos \phi \cot \phi)}{(\cos \phi \cos b + \cos \phi \sin b \tan T - \cos \phi)}$$

Solving these equations for, and then eliminating,  $\tan T$  results in the equation for Babylonian hour-lines:

$$g_1 y \sin \phi \cos \phi (1 - \cos b) - g_2 x \sin b \cos \phi = g_1 g_2 (\sin^2 \phi + \cos^2 \phi \cos b) \quad (12)$$

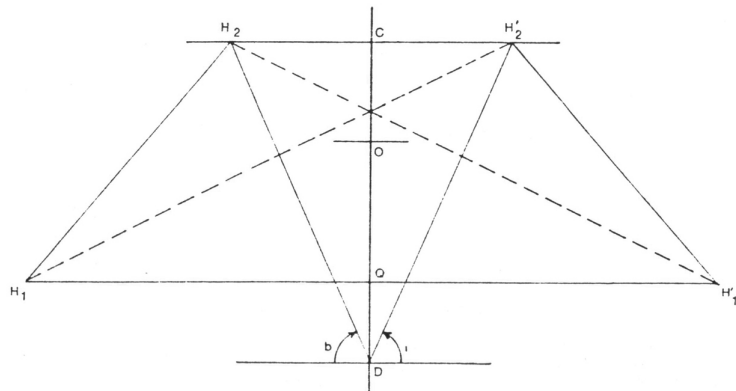

FIGURE 4.

TABLE VI

CO-ORDINATES OF SELECTED POINTS FOR THE CONSTRUCTION OF BABYLONIAN AND ITALIAN HOUR-LINES

Point	General Case		Special Case	
	X	Y	X	Y
Q	0	$-g_2 \cot \phi$	0	-1
C	0	$g_2 \tan \phi$	0	$\tan^2 \phi$
D	0	$g_2 \tan \phi - g_1 \sec \phi$	0	-1

By similar reasoning for the (reverse-numbered) Italian hours  $i$ :  $T$  may also be viewed as the time from noon to sunset; so  $t = T - i$  and the resulting equation is:

$$g_1 y \sin \phi \cos \phi (1 - \cos i) + g_2 x \sin i \cos \phi = g_1 g_2 (\sin^2 \phi + \cos^2 \phi \cos i) \quad (13)$$

Both families of hour-lines are linear; however, neither the Babylonian nor the Italian hour-lines have a common point of intersection, as is the case for the usual astronomical hour-lines. The angles  $\beta$  and  $\iota$  that they respectively make with the line QON are as follows:

$$\tan \beta = (g_1/g_2) \sin \phi \tan \frac{1}{2}b \quad \tan \iota = -(g_1/g_2) \sin \phi \tan \frac{1}{2}i$$

Thus, if  $g_2 = g_1 \sin \phi$ , the hour-lines are equiangular in the sense that  $\beta$  and  $\iota$  are proportional to  $b$  and  $i$ , respectively.

Michnik gives a graphic means of drawing these hour-lines for special values of  $g_1$  and  $g_2$ ; it may be generalized as follows. In figure 4 let O be the origin as before. Table VI lists the co-ordinates of the points Q, C and D in the general case and in the special case in which  $g_2 = \tan \phi$  and  $g_1 = \sec \phi$ . Construct lines  $CH_2$  and  $QH_1$  perpendicular to QC and let  $H_2$  be the point of intersection of line  $DH_2$  with line  $CH_2$ , where the angle  $CDH_2 = b - 90^\circ$ . Let point  $H_1$  be such that  $\overline{QH_1} = \overline{DH_2}$ . The Babylonian hour-line for hour  $b$  is  $H_1H_2$ .

A similar construction, symmetric about the line QC and yielding points  $H_1'$  and  $H_2'$  works for Italian hour-lines.

To justify these constructions it suffices to show that points  $H_1$  and  $H_2$  as well as the symmetrically placed points  $H_1'$  and  $H_2'$  lie on the respective hour-lines. From the manner of selecting the points we have:

$$H_1 = (-g_1 \sec \phi \operatorname{cosec} b, -g_2 \cot \phi)$$

$$H_2 = (-g_1 \sec \phi \cot b, g_2 \tan \phi)$$

$$H_1' = (g_1 \sec \phi \operatorname{cosec} i, -g_2 \cot \phi)$$

$$H_2' = (g_1 \sec \phi \cot i, g_2 \tan \phi)$$

It is now a simple matter to verify that the co-ordinates of these points satisfy the equations (12) and (13) for the appropriate hour-lines.

It should also be noted that each of the four hour-lines obtainable from these points may be viewed as either Babylonian or Italian (see

Table VII). Although there are no lines corresponding to sunrise ( $b = 0^\circ$ ) or to sunset ( $i = 0^\circ$ ), the same line, given by the following equation, represents the twelfth hours after sunrise and before sunset:

$$y = g_2 (\tan \phi - \cot \phi)/2$$

Figure 5 displays Babylonian hour-lines, numbered clockwise, and Italian hour-lines, numbered counterclockwise, for a bifilar dial at latitude  $40^\circ\text{N}$  with  $g_1 = \sec \phi$  and  $g_2 = \tan \phi$ .

TABLE VII

HOURLINES OBTAINABLE FROM A SINGLE CONSTRUCTION

Line	Babylonian Hour	Italian Hour
$H_1H_2$	$b$	$360^\circ - b$
$H_1H'_2$	$180^\circ - b$	$180^\circ + b$
$H'_1H_2$	$180^\circ + b$	$180^\circ - b$
$H'_1H'_2$	$360^\circ - b$	$b$

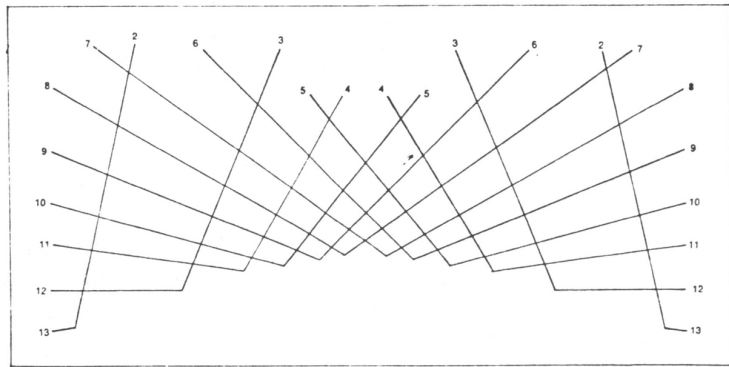

FIGURE 5. Babylonian and Italian hour-lines for  $\phi = 40^\circ\text{N}$ .

### Sidereal hour-lines

Finally<sup>f</sup>, we will consider one more system of indicating time: sidereal hours. It is a fact well known to diallers that the length of the solar day, defined as the time between successive meridian-crossings by the Sun, is not constant. Because the Sun appears to have a non-uniform motion of its own along the ecliptic with respect to the fixed stars, the so-called Equation of Time must be added to the sundial's reading to obtain a result which increases uniformly. The chief advantage of an equiangular dial is that it affords an easy means of making the desired correction in the reading.

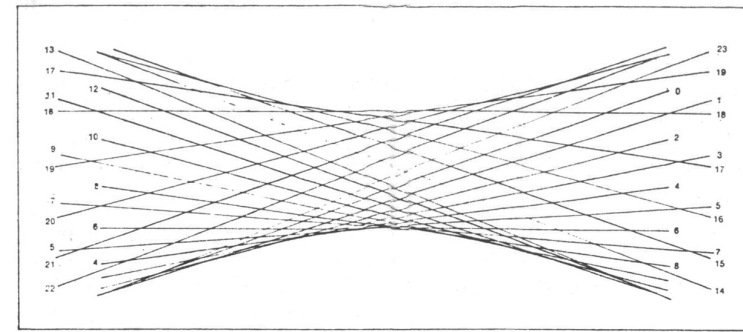

FIGURE 6. Sidereal hour-lines for  $\phi = 40^\circ\text{N}$ .

Suppose, however, that the day is now defined as the interval between successive crossings of the meridian by a fixed point on the ecliptic—in particular, by the vernal point, *i.e.* the Sun's position on the day of the vernal equinox, which corresponds to the intersection of the ecliptic and celestial equator. This so-called sidereal day is of interest primarily in astronomical contexts; its length is constant and, on the average, is approximately 3 minutes 56 seconds shorter than a solar day. By definition, the local sidereal hour  $\theta$  is the hour-angle of the vernal point. For any astronomical body, and in particular for the Sun,  $\theta$  is equal to the body's hour-angle  $t$  (the angle west of the meridian measured along the equator) plus its right ascension  $\alpha$  (the angle east of the vernal point measured along the equator).

To obtain an equation for sidereal hour-lines we begin with the equations relating  $\theta$  to the Sun's hour-angle, right ascension and declination.

$$t = \theta - \alpha \quad \tan \delta = \tan \epsilon \sin \alpha \quad (\epsilon = 23;26^\circ)$$

At this point, we proceed as before; using these equations for substitutions in (10) and (11), we obtain:

$$x = \frac{g_1 (\sin \theta - \cos \theta \tan \alpha)}{(\sin \phi \tan \epsilon + \cos \phi \sin \theta) \tan \alpha + \cos \phi \cos \theta}$$

$$y = \frac{g_2 ((\sin \phi \sin \theta - \cos \phi \tan \epsilon) \tan \alpha + \sin \phi \cos \theta)}{(\sin \phi \tan \epsilon + \cos \phi \sin \theta) \tan \alpha + \cos \phi \cos \theta}$$

Eliminating  $\tan \alpha$  yields the equation for the sidereal hour-lines:

$$g_2 x \cos \theta \tan \epsilon - g_1 y (\cos \phi + \sin \phi \sin \theta \tan \epsilon) = g_1 g_2 (\cos \phi \sin \theta \tan \epsilon - \sin \phi) \quad (14)$$

The equation<sup>g</sup> is linear in  $x$  and  $y$ ; in the special case of  $\phi = 90^\circ - \epsilon$ , these lines coincide with the Babylonian (for  $\theta = b - 90^\circ$ ) and Italian (for

$\theta = 270^\circ - i$ ) hour-lines. Sidereal hour-lines for latitude  $40^\circ\text{N}$  under the assumptions  $g_1 = \sec \phi$  and  $g_2 = \tan \phi$  are drawn in figure 6.

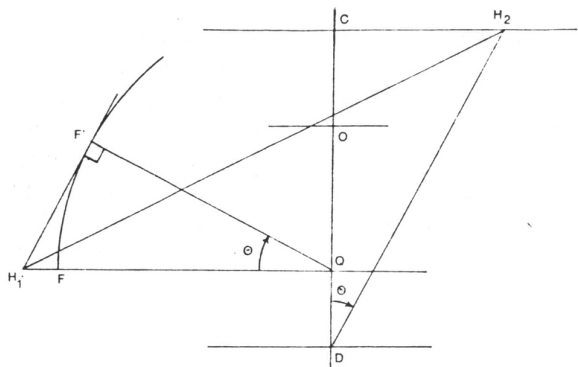

FIGURE 7.

A graphic construction of these lines similar to the one given for Babylonian hour-lines may be developed as follows<sup>h</sup>. In figure 7 let O be the origin and let points Q, C, D and F have the co-ordinates listed in Table VIII, where the special case is the one which generates figure 6. Construct lines  $CH_2$  and  $QF$  perpendicular to  $QC$ . Let  $H_2$  be the intersection of lines  $CH_2$  and  $DH_2$ , where the angle  $CDH_2 = \theta$ . Let  $H_1$  be the intersection of the line  $QF$  with the tangent to the circle (with centre Q and radius  $\overline{QF}$ ) at point  $F'$ , where the angle  $QFQ' = \theta$ . The sidereal hour-line for hour  $\theta$  is  $H_1H_2$ . For the limiting cases when these points are at infinity, the hour-lines have the following equations:

$$\begin{aligned} \theta = 90^\circ &\rightarrow y = g_2 \tan(\phi - \epsilon) \\ \theta = 270^\circ &\rightarrow y = g_2 \tan(\phi + \epsilon) \end{aligned}$$

TABLE VIII

CO-ORDINATES OF SELECTED POINTS FOR THE CONSTRUCTION OF SIDEREAL HOUR-LINES

Point	General Case		Special Case	
	X	Y	X	Y
Q	0	$-g_2 \cot \phi$	0	-1
C	0	$g_2 \tan \phi$	0	$\tan^2 \phi$
D	0	$g_2 \tan \phi - g_1 \sec \phi$	0	-1
F	$-g_1 \operatorname{cosec} \phi \cot \epsilon$	$-g_2 \cot \phi$	$-\sec \phi \operatorname{cosec} \phi \cot \epsilon$	-1

To justify the construction, it suffices to determine that the points  $H_1$  and  $H_2$  satisfy equation (14).

$$\begin{aligned} H_1 &= (-g_1 \operatorname{cosec} \phi \sec \theta \cot \epsilon, -g_2 \cot \phi) \\ H_2 &= (g_1 \sec \phi \tan \theta, g_2 \tan \phi) \end{aligned}$$

TABLE IX

HOURLINES OBTAINABLE FROM A SINGLE CONSTRUCTION

Line	Sidereal Hour
$H_1H_2$	$\theta$
$H_1H'_2$	$360^\circ - \theta$
$H'_1H_2$	$180^\circ + \theta$
$H'_1H'_2$	$180^\circ - \theta$

If we consider the points  $H_1'$  and  $H_2'$  as before, we see that each construction actually gives us four hour-lines (see Table IX).

Perhaps the primary interest of these hour-lines is that they demonstrate that a sundial is capable of recording time uniformly despite the fact that the apparent position of the Sun changes non-uniformly<sup>i</sup>. No correction needs to be made to the dial reading to obtain sidereal time. The value of  $\theta$  at local noon on the vernal equinox is  $0^\circ$ ; it continues to increase throughout the succeeding year, having a value of  $90^\circ$  on the summer solstice,  $180^\circ$  on the autumn equinox and  $270^\circ$  on the winter solstice.

#### Notes

- See ref. 10. Other references to bifilar dials include 1 (p. 105) and 2 (p. 135). Another brief geometrical treatment (ref. 5) of the basic equiangular dial appeared while the present article was in the hands of the referee.
- Dials of this type are discussed in ref. 11, where the treatment is not restricted to horizontal examples. This type of dial was invented in the seventeenth-century by Samuel Foster<sup>3</sup> but is often attributed to the eighteenth-century mathematician and philosopher J. H. Lambert<sup>7</sup>. The dial is discussed in ref. 1, and there have been a number of more recent studies of it, the most extensive being refs 4, 6 and 11.
- As a practical addition to the dial, one should consider some form of alidade or pointer free to rotate as a diameter of the dial face. If a line is drawn down the middle of the alidade, it can be turned until the intersection of the shadows lies on the line and the end of the alidade indicates the time on the circumference of the dial face. This addition would eliminate the need for drawing an excessive number of hour-lines. It should be noted that the heights of the threads must be measured from the upper surface of the alidade rather than from the surface of the dial proper.  
Another practical point to make here is that if the threads are attached to the tops of their supports, the shadows of the supports will not obliterate any readings. However, if the supports extend above the threads, care should be taken to insure against problems caused by the shadows.
- The astronomical hour-lines for a dial at latitude  $\phi$  with inclination  $i$  and declination  $d$  are given by the equation  
$$g_1 g_2 \cos \alpha = g_2 \cot(t - t') - g_1 y \sin \alpha$$
where  $\alpha$  and  $t'$  are given by equations (4) and (5).

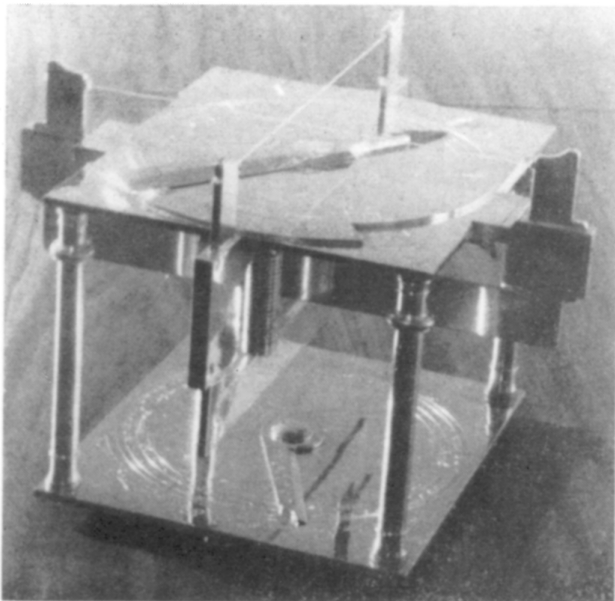

FIGURE 8. An equiangular bifilar sundial designed by M. U. Zakariya and the author. The dial is on the upper plate with hours marked around the circumference. The alidade has a line down its centre and must be turned until the intersection of the shadows of the threads lies on that line. The height and position of the threads are adjusted by micrometers on the underside of the plate, according to the latitude of the dial's location; adjustments for longitude and the equation of time are made with verniers on the dial face. The lower plate gives the equation of time. This dial is the first of a small series of bifilar dials to be constructed by Mr Zakariya.

- (h) For a somewhat different construction and development of sidereal hour-lines for non-bifilar sundials, see ref. 9.
- (i) For the use to which such a sundial may be put in astrology, see ref. 1 (chapter XIV).

#### References

- 1 Drecker, J., *Die Theorie der Sonnenuhren*, Berlin, 1925.
- 2 Drecker, J., *Zeitmessung und Sternedeutung in geschichtlicher Darstellung*, Berlin, 1925.
- 3 Foster, S., *Elliptical, or azimuthal horologigraphy*, London, 1654.
- 4 Hanke, W., *Die Sterne*, 51, 159 (1975).
- 5 Hanke, W., *Die Sterne*, 52, 228 (1976).
- 6 Janin, L., *Le Cadran Solaire Analemattique—Histoire et Développements*. Note 74.2057. Besançon, France: Centre Technique de l'Industrie Horlogère, 1974.
- 7 Lambert, J., *Berliner Astronomisches Jahrbuch für 1777*, 200. Berlin, 1775.
- 8 Michnik, H., *Beiträge zur Theorie der Sonnenuhren*. Leipzig, 1914.
- 9 Michnik, H., *Astronomische Nachrichten*, 216, 441 (1922).
- 10 Michnik, H., *Astronomische Nachrichten*, 217, 81 (1923).
- 11 Taylor, G., *J. Br. astron. Assoc.*, 86, 7 (1975).

- (e) The day curve for a non-horizontal dial is

$$\sin^2 \delta (g_2^2 x^2 + g_1^2 y^2 + g_1^2 g_2^2) = g_1^2 (g_2 \sin a - y \cos a)^2$$

where  $a$  is given by equation (4).

- (f) Michnik also considers temporary or unequal hour-lines, which result from dividing the period of daylight on any given day into 12 equal hours. The lines are given by higher-order algebraic equations (although they are often approximated by straight lines) and will not be considered here. They are treated in detail for the case of non-bifilar dials in ref. 8; the modification required to adapt them to the bifilar case is discussed in ref. 10.

- (g) The equation for sidereal hour-lines for non-horizontal dials is

$$g_2 x \cos(\theta - t') \tan \epsilon - g_1 y (\cos a + \sin a \sin(\theta - t') \tan \epsilon) = g_1 g_2 (\cos a \sin(\theta - t') \tan \epsilon - \sin a)$$

where  $a$  and  $t'$  are given by equations (4) and (5).

Reproduced by permission of British Astronomical Association, from *J. Brit Astronomical Association* 1978, 88, 4, pp. 334-351.

## USEFUL ADDRESSES

Mr. Charles K. Aked 54 Swan Road WEST DRAYTON Middlesex UB7 7JZ	[Editor]	Tel: 0895 445332
Mr. C. St. J.H. Daniel 57 Gossage Road PLUMSTEAD COMMON London SE18 1NQ	[Chairman]	Tel: 081 3178779
Mr. R.A. Nicholls 45 Hound Street SHERBORNE Dorset DT9 3AB	[Treasurer]	Tel: 0935 812544
Mr. P. Nicholson 9 Lynwood Avenue EPSOM Surrey KT17 4LQ	[Sponsorship]	Tel: 037 27 25742
Mrs. Anne Somerville Mendota Middlewood Road HIGHER POYNTON Cheshire SK12 1TX	[Library, Archival Records & Sales]	Tel: 0625 872943
Mr. Robert B. Sylvester Barncroft Grizebeck KIRKBY-IN-FURNESS Cumbria LA17 7XJ	[Membership]	Tel: 0229 89716
Mr. G.E. Taylor Five Firs Cinderford Lane Cowbeech HAILSHAM East Sussex BN27 4HL	[Dial Recording]	Tel: 0323 833255
Mrs. Jane Walker 31 Langdown Road Little Sandhurst CAMBERLEY Surrey GU17 8QG	[Education]	Tel: 0344 772569
Dr. I.D.P. Wootton Cariad Cottage Cleeve Road GORING-ON-THAMES Oxon RG8 9BD	[Registrar]	Tel: 0491 873050
Mr. D.A. Young Brook Cottage 112 Whitehall Road CHINGFORD London E4 6DW	[Secretary]	Tel: 081 529 4880